

Original instructions
PAEC3200C

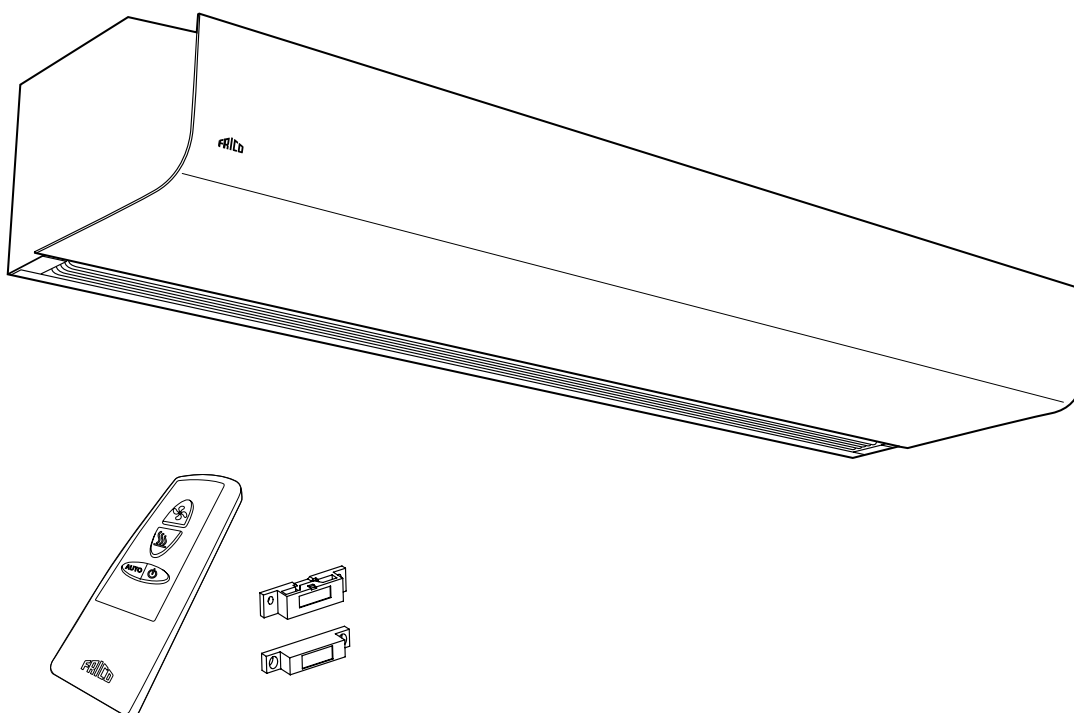

EN 17

FR 23

ES 32



Frico AB certifies that the PAEC3200CA, PAEC3200CE and PAEC3200CW air curtains shown herein are licensed to bear the AMCA Seal. The ratings shown are based on tests and procedures performed in accordance with AMCA Publication 211 and AMCA Publication 311 and comply with the requirements of the AMCA Certified Ratings Program. The AMCA Certified Ratings Seal applies to airflow rate, average outlet velocity, outlet velocity uniformity, velocity projection and power rating at free delivery only.

Metric chart

☼ Ambient, no heat - PAEC3200CA (IP21)

Type	Output [kW]	Airflow* ¹ [m ³ /h]	Sound power* ² [dB(A)]	Motor power [W]	Voltage motor [V]	Amperage motor [A]	Weight [kg]
PAEC3210CA-NA	0	1750	73	135	208V~	0.9	22
PAEC3215CA-NA	0	2450	72	147	208V~	0.9	32
PAEC3220CA-NA	0	3500	75	270	208V~	1.8	42

⚡ Electrical heat - PAEC3200CE (IP20)

Type	Output steps [kW]	Airflow* ¹ [m ³ /h]	Sound power* ² [dB(A)]	FLA (full load amperage)* ³ [A]	Motor power [W]	Amperage motor [A]	Voltage [V] Amperage [A] (heat)	Weight [kg]
PAEC3210CE07-208VNA	4/7	1750	73	21	135	0.9	208V3~/19	26
PAEC3215CE10-208VNA	7/10	2450	72	29	147	0.9	208V3~/28	37
PAEC3220CE13-208VNA	8/13	3500	75	39	270	1.7	208V3~/36	51
PAEC3210CE08-480VNA	4/8	1750	73	11	135	0.9	480V3~/10	26
PAEC3215CE12-480VNA	6/12	2450	72	16	147	0.9	480V3~/15	37
PAEC3220CE16-480VNA	8/16	3500	75	21	270	1.7	480V3~/20	51
PAEC3210CE08-600VNA	4/8	1750	73	9	135	0.9	600V3~/8	26
PAEC3215CE12-600VNA	6/12	2450	72	13	147	0.9	600V3~/12	37
PAEC3220CE16-600VNA	8/16	3500	75	17	270	1.7	600V3~/16	51

💧 Water heat - PAEC3200CW (IP21)

Type	Output* ⁴ [kW]	Airflow* ¹ [m ³ /h]	Sound power* ² [dB(A)]	Motor power [W]	Voltage motor [V]	Amperage motor [A]	Water volume [l]	Weight [kg]
PAEC3210CW-NA	8	1460	72	109	208V~	0.7	1.3	26
PAEC3215CW-NA	14	2150	72	135	208V~	0.9	2.1	36
PAEC3220CW-NA	19	2920	74	218	208V~	1.4	2.7	48

*¹) Highest airflow of totally 3 fan steps.

*²) Values shown are for total sound power levels for Installation Type A: free inlet, free outlet. The Sound power level ratings shown are in decibels, referred to 10-12 watts, calculated per AMCA Standard 301.

*³) FLA: total amperage for motor and heat.

*⁴) Applicable at water temperature 60/40 °C, air temperature, in +18 °C.

Above table is valid for 208V/1ph/60Hz. Also approved for 230V/1ph/60Hz. Product performance for 230V/1ph/60Hz will differ from stated data.

Protection class for units with electrical heating: IP20.

Protection class for units without heating and units with water heating: IP21.

CE compliant.

PAEC3200C

Type	Nozzle depth and width [mm]	Max velocity at nozzle [m/s]	Outlet velocity [m/s]	Outlet velocity uniformity [%]
PAEC3210CA-NA/PAEC3210CExx	65x975	11.92	10.03	81
PAEC3215CA-NA/PAEC3215CExx	65x1485	11.52	9.45	80
PAEC3220CA-NA/PAEC3220CExx	65x1975	11.92	10.03	81
PAEC3210CW-NA	65x975	11.00	9.07	75
PAEC3215CW-NA	65x1485	9.10	7.85	82
PAEC3220CW-NA	65x1975	11.00	9.07	75

Velocity projection: Model PAEC3210CE/CA-NA

Distance from nozzle [mm]	65	500	1000
Core velocity [m/s]	10.03	7.75	5.58
Uniformity [%]	81	84	86

Velocity projection: Model PAEC3210CW-NA

Distance from Nozzle [mm]	65	500	1000
Core Velocity [m/s]	9.07	6.95	4.99
Uniformity [%]	75	87	90



Frico AB certifies that the PAEC3200CA, PAEC3200CE and PAEC3200CW air curtains shown herein are licensed to bear the AMCA Seal. The ratings shown are based on tests and procedures performed in accordance with AMCA Publication 211 and AMCA Publication 311 and comply with the requirements of the AMCA Certified Ratings Program. The AMCA Certified Ratings Seal applies to airflow rate, average outlet velocity, outlet velocity uniformity, velocity projection and power rating at free delivery only.

Imperial chart

🌀 Ambient, no heat - PAEC3200CA (IP21)

Type	Output [MBH]	Airflow* ¹ [cfm]	Sound power* ² [dB(A)]	Motor power [W]	Voltage motor [V]	Amperage motor [A]	Weight [lb]
PAEC3210CA-NA	0	1150	73	135	208V~	0.9	49
PAEC3215CA-NA	0	1600	72	147	208V~	0.9	71
PAEC3220CA-NA	0	2250	75	270	208V~	1.8	93

⚡ Electrical heat - PAEC3200CE (IP20)

Type	Output steps [MBH]	Airflow* ¹ [cfm]	Sound power* ² [dB(A)]	FLA (full load amperage)* ³ [A]	Motor power [W]	Amperage motor [A]	Voltage [V] Amperage [A] (heat)	Weight [lb]
PAEC3210CE07-208VNA	14/24	1150	73	21	135	0.9	208V3~/19	57
PAEC3215CE10-208VNA	24/34	1600	72	29	147	0.9	208V3~/28	82
PAEC3220CE13-208VNA	27/44	2250	75	39	270	1.7	208V3~/36	112
PAEC3210CE08-480VNA	14/27	1150	73	11	135	0.9	480V3~/10	57
PAEC3215CE12-480VNA	20/41	1600	72	16	147	0.9	480V3~/15	82
PAEC3220CE16-480VNA	27/55	2250	75	21	270	1.7	480V3~/20	112
PAEC3210CE08-600VNA	14/27	1150	73	9	135	0.9	600V3~/8	57
PAEC3215CE12-600VNA	20/41	1600	72	13	147	0.9	600V3~/12	82
PAEC3220CE16-600VNA	27/55	2250	75	17	270	1.7	600V3~/16	112

💧 Water heat - PAEC3200CW (IP21)

Type	Output* ⁴ [MBH]	Airflow* ¹ [cfm]	Sound power* ² [dB(A)]	Motor power [W]	Voltage motor [V]	Amperage motor [A]	Water volume [US gal]	Weight [lb]
PAEC3210CW-NA	27	1050	72	109	208V~	0.7	0.34	57
PAEC3215CW-NA	48	1550	72	135	208V~	0.9	0.55	79
PAEC3220CW-NA	65	2150	74	218	208V~	1.4	0.71	106

*¹) Highest airflow of totally 3 fan steps.

*²) Values shown are for total sound power levels for Installation Type A: free inlet, free outlet. The Sound power level ratings shown are in decibels, referred to 10-12 watts, calculated per AMCA Standard 301.

*³) FLA: total amperage for motor and heat.

*⁴) Applicable at water temperature 140/104F, air temperature, in +64F.

Above table is valid for 208V/1ph/60Hz. Also approved for 230V/1ph/60Hz. Product performance for 230V/1ph/60Hz will differ from stated data.

Protection class for units with electrical heating: IP20.

Protection class for units without heating and units with water heating: IP21.

CE compliant.

PAEC3200C

Type	Nozzle depth and width [in]	Max velocity at nozzle [fpm]	Outlet velocity [fpm]	Outlet velocity uniformity [%]
PAEC3210CA-NA/PAEC3210CExx	2.6x38.4	2346	1974	81
PAEC3215CA-NA/PAEC3215CExx	2.6x58.5	2267	1860	80
PAEC3220CA-NA/PAEC3220CExx	2.6x77.8	2346	1974	81
PAEC3210CW-NA	2.6x38.4	2165	1785	75
PAEC3215CW-NA	2.6x58.5	1791	1545	82
PAEC3220CW-NA	2.6x77.8	2165	1785	75

Velocity projection: Model PAEC3210CE/CA-NA

Distance from Nozzle [in]	2.5	20	40
Core Velocity [fpm]	1968	1525	1098
Uniformity [%]	81	84	86

Velocity projection: Model PAEC3210CW-NA

Distance from Nozzle [in]	2.5	20	40
Core Velocity [fpm]	1785	1368	982
Uniformity [%]	75	87	90



Frico AB certifies that the PAEC3200CA, PAEC3200CE and PAEC3200CW air curtains shown herein are licensed to bear the AMCA Seal. The ratings shown are based on tests and procedures performed in accordance with AMCA Publication 211 and AMCA Publication 311 and comply with the requirements of the AMCA Certified Ratings Program. The AMCA Certified Ratings Seal applies to airflow rate, average outlet velocity, outlet velocity uniformity, velocity projection and power rating at free delivery only.

Output charts water PAEC3200CW

Metric chart

			Supply water temperature: 80 °C Room temperature: +18 °C Outlet air temperature: +35 °C*1				Water temperature: 80/60 °C Room temperature: +18 °C			
Type	Fan position	Airflow	Output	Return water temp.	Water flow	Pressure drop	Output*2	Outlet air temp.	Water flow	Pressure drop
		[m³/h]	[kW]	[°C]	[l/s]	[kPa]	[kW]	[°C]	[l/s]	[kPa]
PAEC3210CW-NA	max	1460	10.0	42	0.06	1.4	14.9	42	0.18	8.8
PAEC3215CW-NA	max	2150	15.3	38	0.09	2.0	24.2	45	0.30	16.2
PAEC3220CW-NA	max	2920	21.2	38	0.12	2.6	33.4	44	0.41	21.6

			Supply water temperature: 60 °C Room temperature: +18 °C Outlet air temperature: +35 °C*1				Water temperature: 60/40 °C Room temperature: +18 °C			
Type	Fan position	Airflow	Output	Return water temp.	Water flow	Pressure drop	Output*2	Outlet air temp.	Water flow	Pressure drop
		[m³/h]	[kW]	[°C]	[l/s]	[kPa]	[kW]	[°C]	[l/s]	[kPa]
PAEC3210CW-NA	max	1460	10.2	48	0.20	10.9	8.2	32	0.10	3.2
PAEC3215CW-NA	max	2150	14.6	42	0.20	8.7	13.6	33	0.17	6.1
PAEC3220CW-NA	max	2920	21.6	45	0.35	17.2	18.9	33	0.23	8.1

*1) Recommended outlet air temperature for good comfort and optimized output.

*2) Nominal output at given supply and return water temperature.

Imperial chart

			Supply water temperature: 176 °F Room temperature: +64 °F Outlet air temperature: +95 °F*1				Water temperature: 176/140 °F Room temperature: +64 °F			
Type	Fan position	Airflow	Output	Return water temp.	Water flow	Pressure drop	Output*2	Outlet air temp.	Water flow	Pressure drop
		[cfm]	[MBH]	[°F]	[US gal/h]	[kPa]	[MBH]	[°F]	[US gal/h]	[kPa]
PAEC3210CW-NA	max	1050	34.1	108	61.3	1.4	50.9	108	173.1	8.8
PAEC3215CW-NA	max	1550	52.2	100	84.6	2.0	82.6	113	280.6	16.2
PAEC3220CW-NA	max	2150	72.4	100	117.9	2.6	114.0	111	388.1	21.6

			Supply water temperature: 140 °F Room temperature: +64 °F Outlet air temperature: +95 °F*1				Water temperature: 140/104 °F Room temperature: +64 °F			
Type	Fan position	Airflow	Output	Return water temp.	Water flow	Pressure drop	Output*2	Outlet air temp.	Water flow	Pressure drop
		[cfm]	[MBH]	[°F]	[US gal/h]	[kPa]	[MBH]	[°F]	[US gal/h]	[kPa]
PAEC3210CW-NA	max	1050	34.8	118	188.3	10.9	28.0	90	94.0	3.2
PAEC3215CW-NA	max	1550	49.8	108	193.1	8.7	46.4	91	156.9	6.1
PAEC3220CW-NA	max	2150	73.7	113	331.9	17.2	64.5	91	217.8	8.1

*1) Recommended outlet air temperature for good comfort and optimized output.

*2) Nominal output at given supply and return water temperature.

EN

The introduction pages consist mainly of pictures. For translation of the English texts used, see the respective language pages.

FR

Les pages de présentation contiennent principalement des images. Pour la traduction des textes en anglais, consultez la page correspondante à la langue souhaitée.

ES

Las páginas introductorias contienen básicamente imágenes. Consulte la traducción de los textos en inglés que las acompañan en las páginas del idioma correspondiente.

PAEC3200C

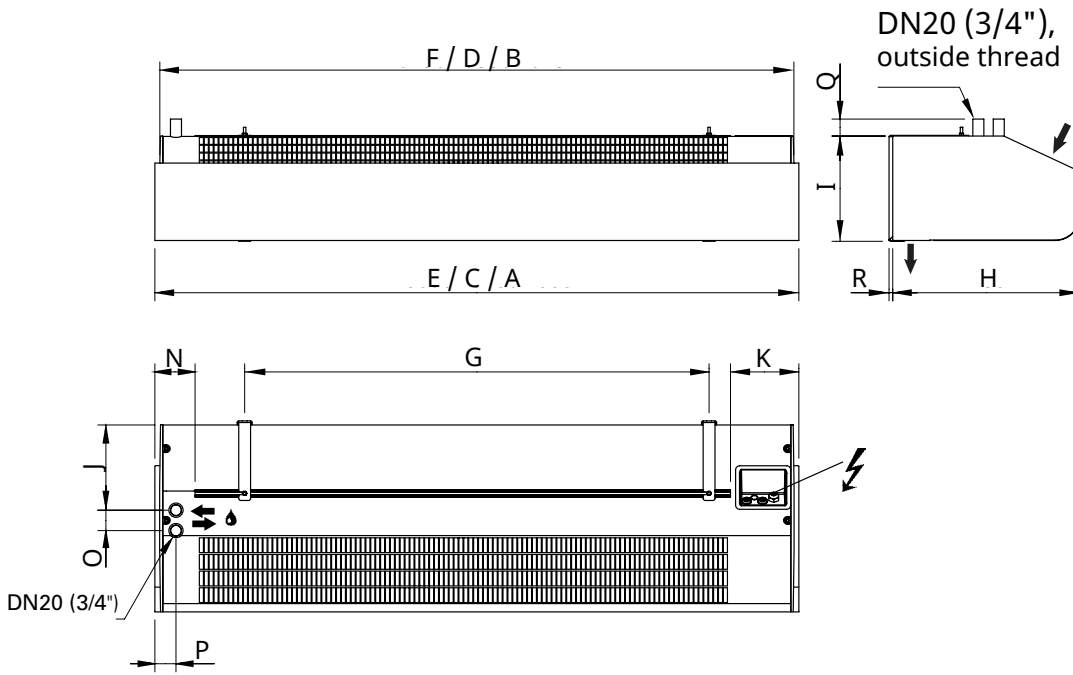

L = 2 m / 6.6 ft

A/W

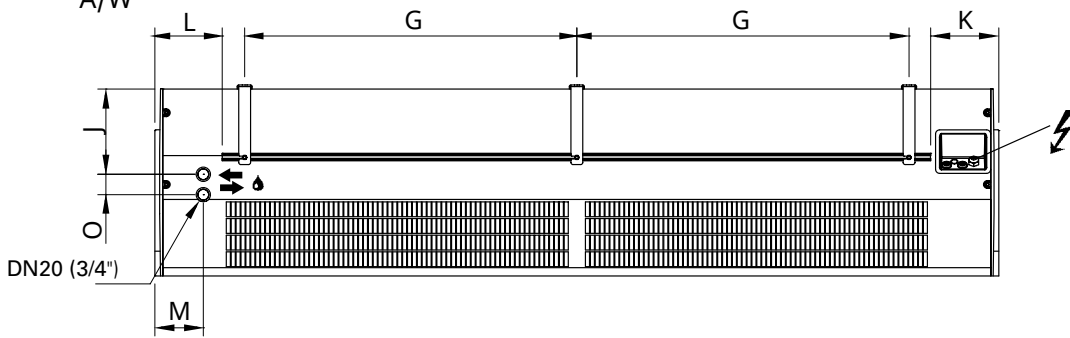

E

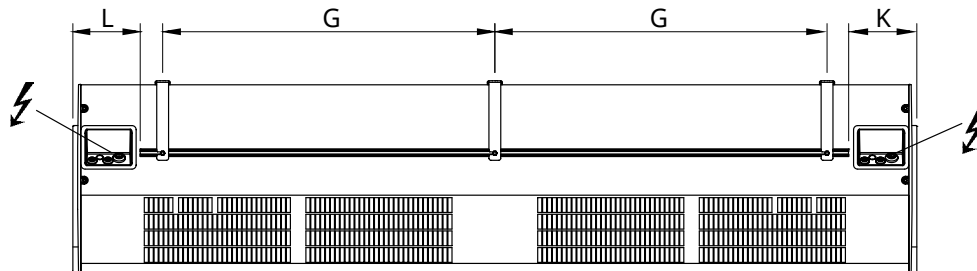

Ref	Metric [mm]	Imperial [in]	Product type
A	2068	81.40	PAEC3220Cx
B	2045	80.50	PAEC3220Cx
C	1578	62.10	PAEC3215Cx
D	1555	61.20	PAEC3215Cx
E	1068	42.00	PAEC3210Cx
F	1045	41.10	PAEC3210Cx
G	500	19.68	
H	458	18.00	
I	256	10.00	
J	209	8.22	

Ref	Metric [mm]	Imperial [in]
K	167	6.57
L	165	6.49
M	119	4.68
N	99	3.89
O	50	1.96
P	52	2.00
Q	42	1.65
R	10	0.39

Ref	Metric [mm]	Imperial [in]
A	17.5	0.69
B	20.5	0.81
C	25.5	1.00
D	32.5	1.28

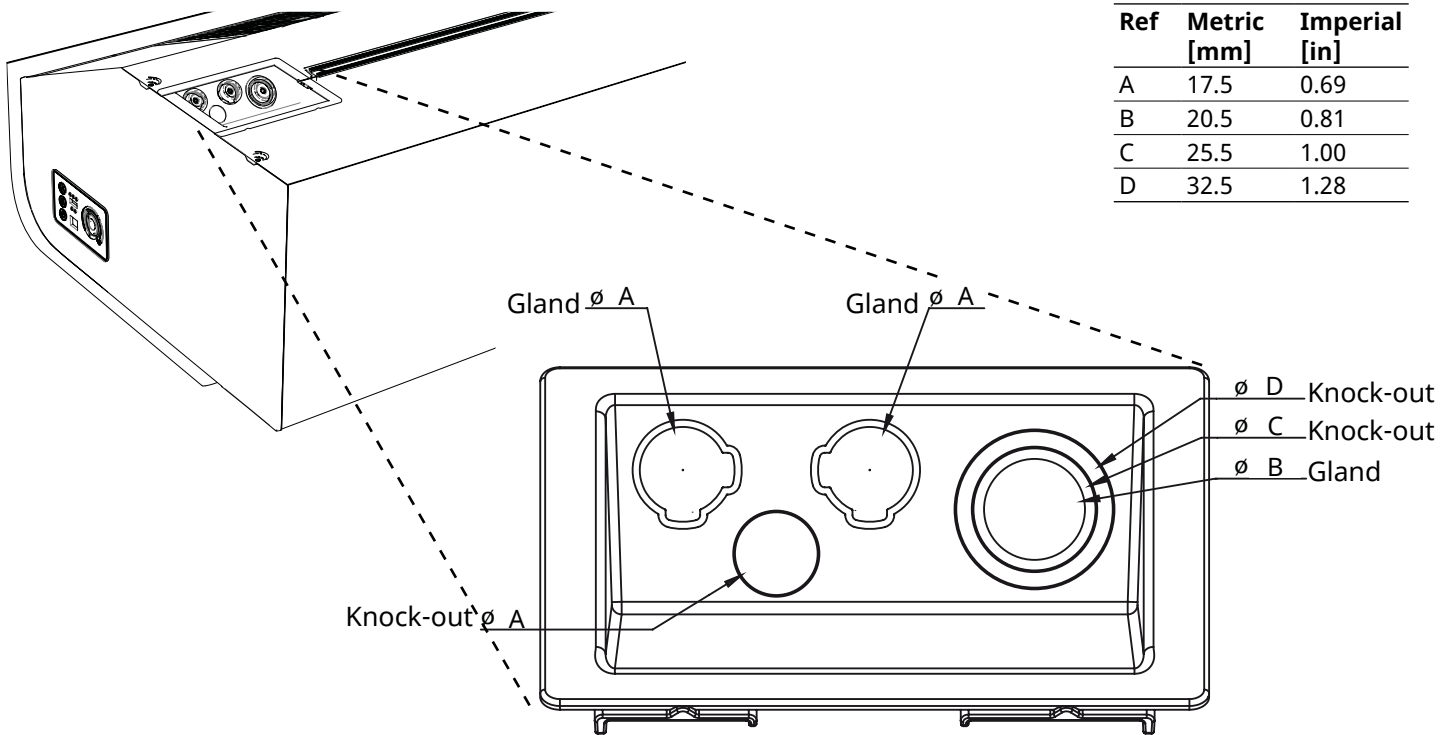

Open the unit

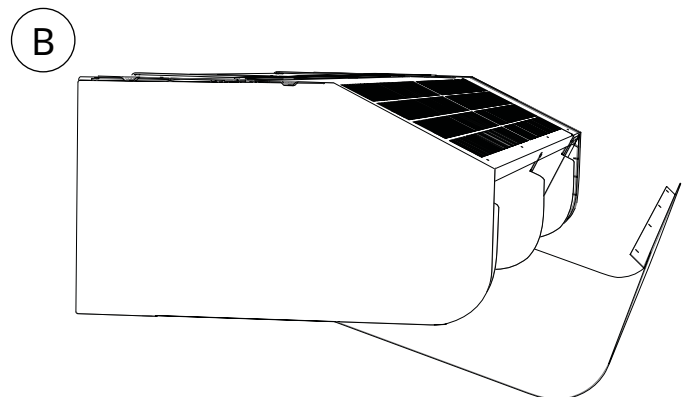
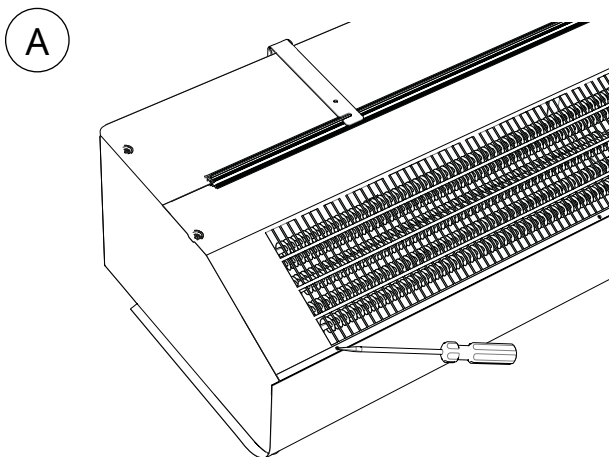

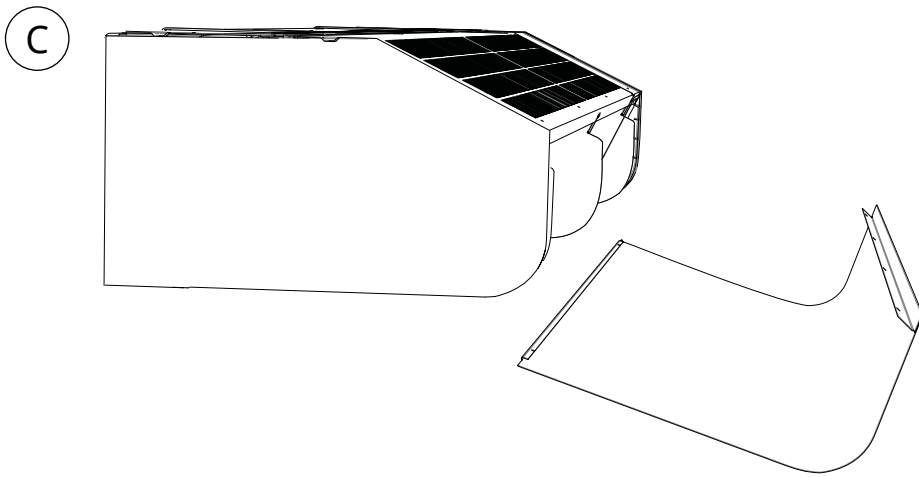

Fig. 3: Open the unit.

Minimum distance

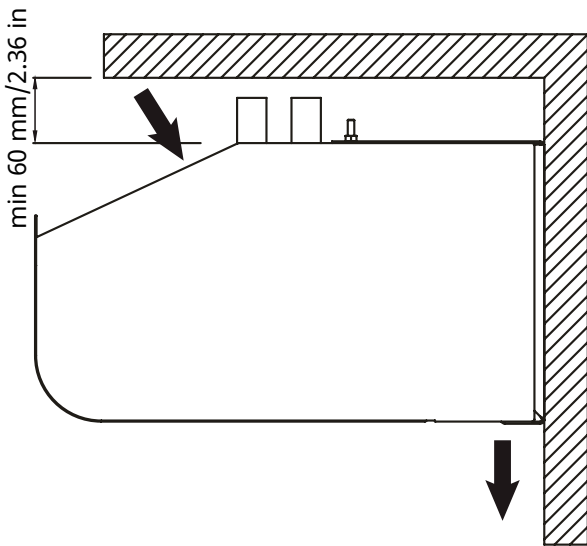

Fig. 4

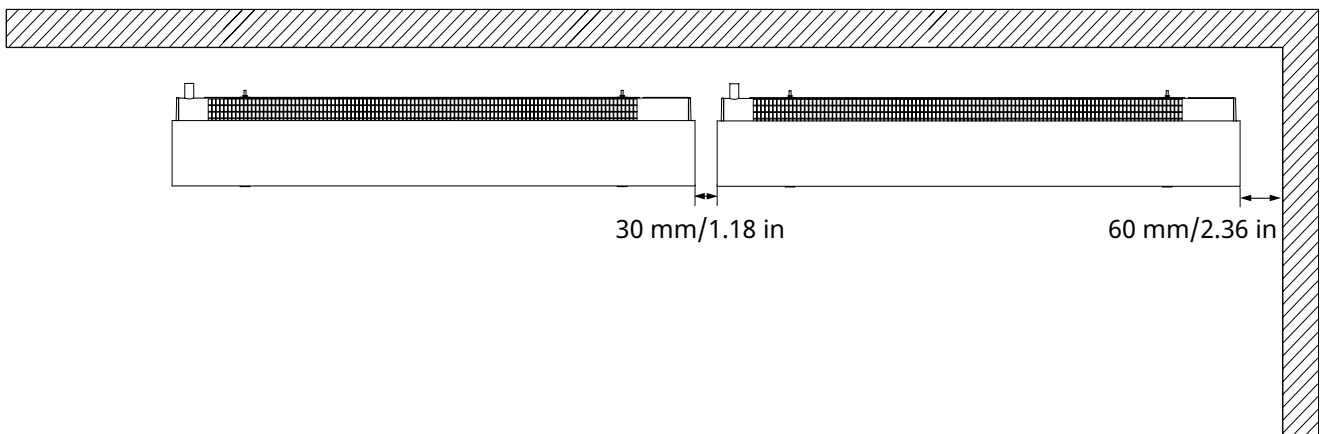
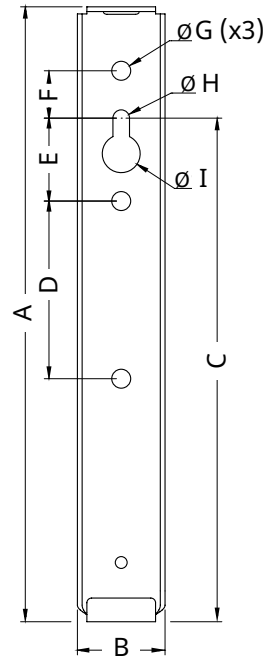
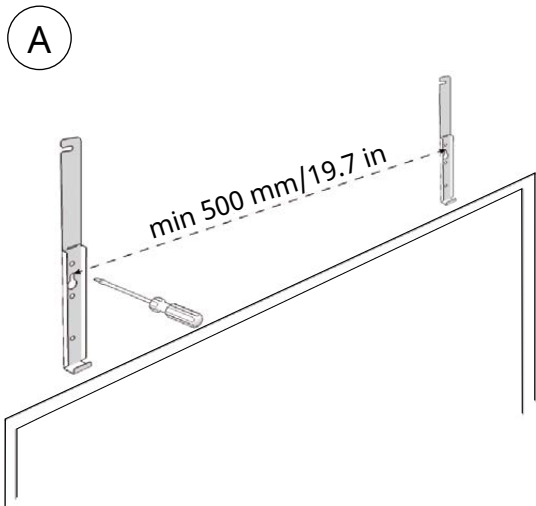

Fig. 5

Mounting with wall brackets



PAEC3210Cx	2 pcs
PAEC3215Cx	2 pcs
PAEC3220Cx	3 pcs

Ref	Metric [mm]	Imperial [in]
A	260	10.24
B	37	1.46
C	213	8.39
D	75	2.95
E	35	1.38
F	20	0.79
G	8	0.31
H	7	0.28
I	16	0.63

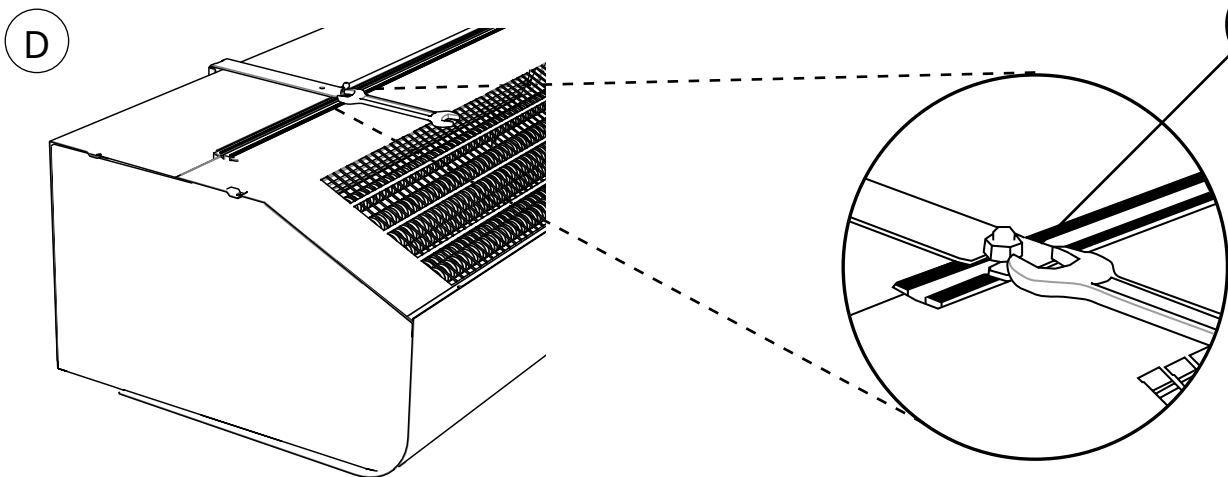
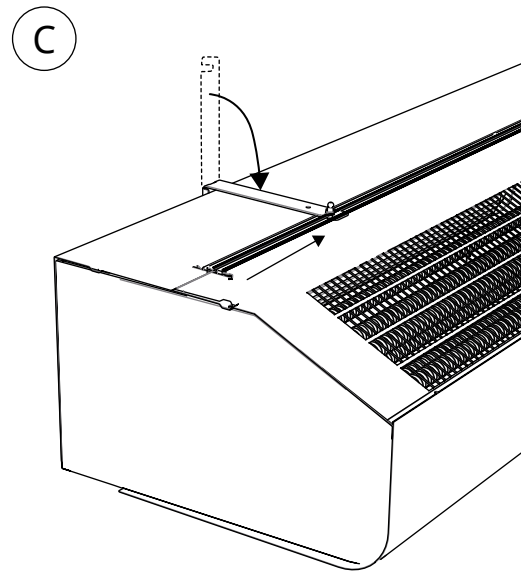
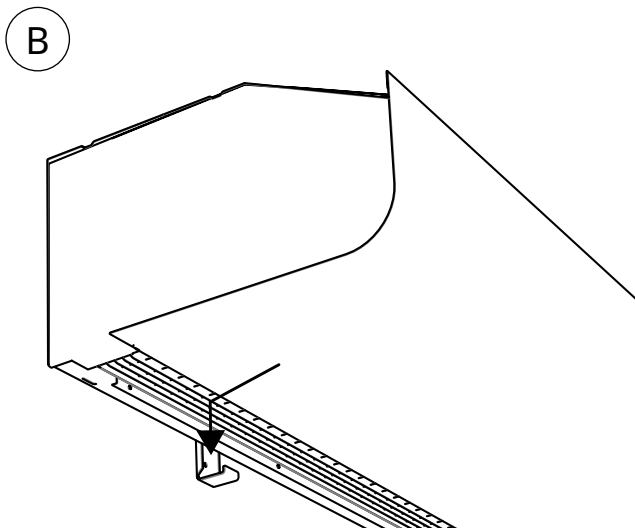

Fig. 6: Mounting with wall brackets

Accessories

PA34TR15	PAEC3210Cx, PAEC3215Cx, 1 m/3.3 ft
PA34TR20	PAEC3220Cx, 1 m/ 3.3 ft
PA2P15	PAEC3210Cx, PAEC3215Cx, 1 m/3.3 ft
PA2P20	PAEC3220Cx, 1 m/3.3 ft
PA3PF15	PAEC3210Cx, PAEC3215Cx
PA3PF20	PAEC3220Cx
PA3EF10	PAEC3210CW
PA3EF15	PAEC3215CW
PA3EF20	PAEC3220CW
FHDN20	PAEC3200CW



PA34TR

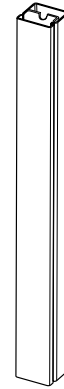

PA2P

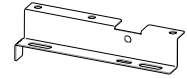

PA3PF

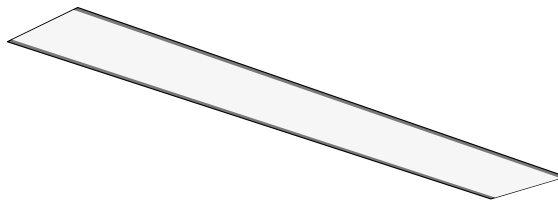

PA3EF

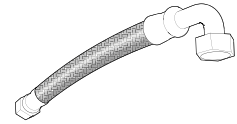

FHDN20



Type	Connection
VLSP15NF-NA	DN15 (1/2")
VLSP20-NA	DN20 (3/4")
VLSP25-NA	DN25 (1")

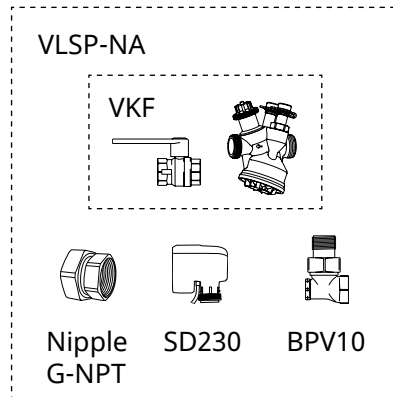

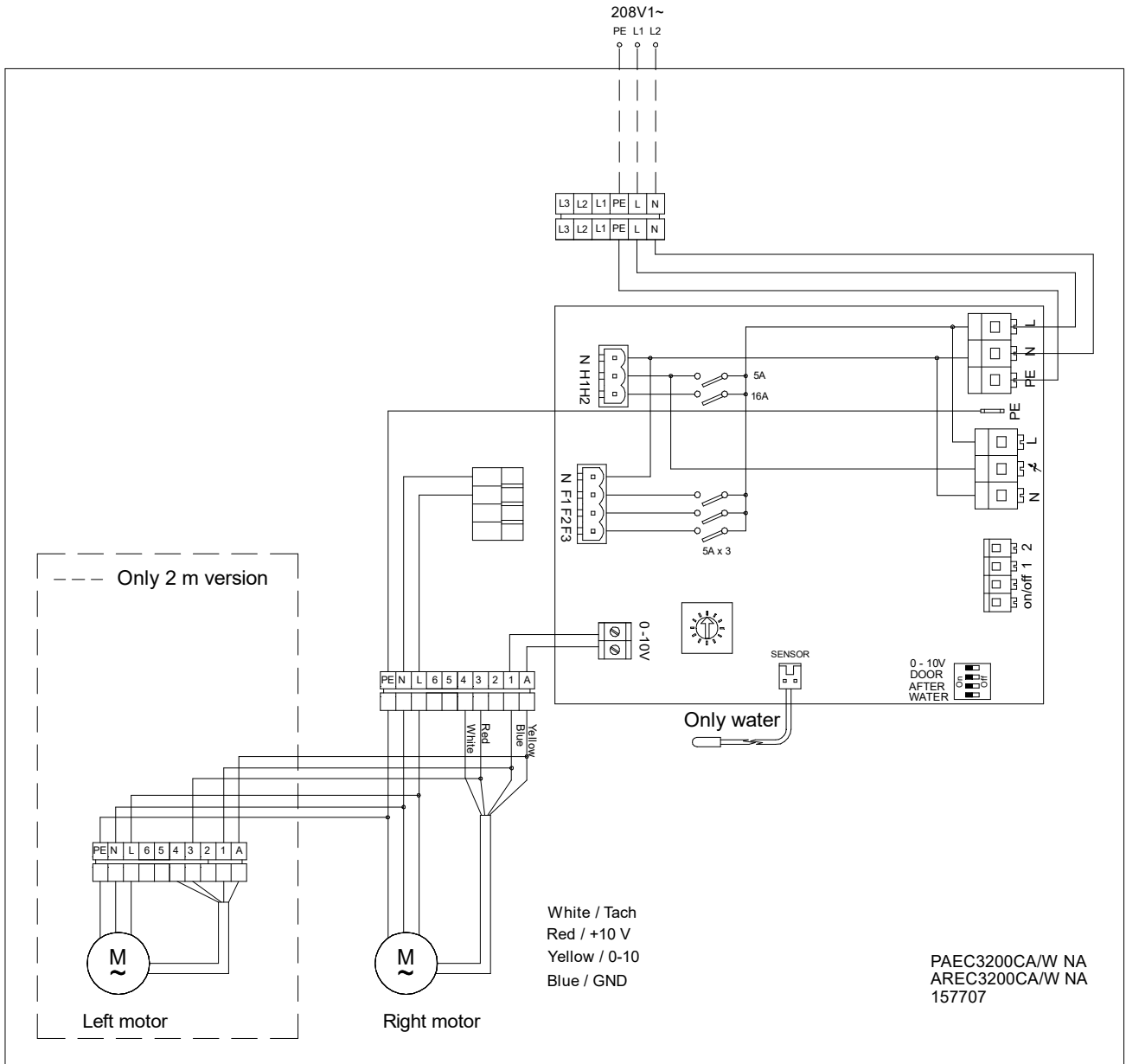

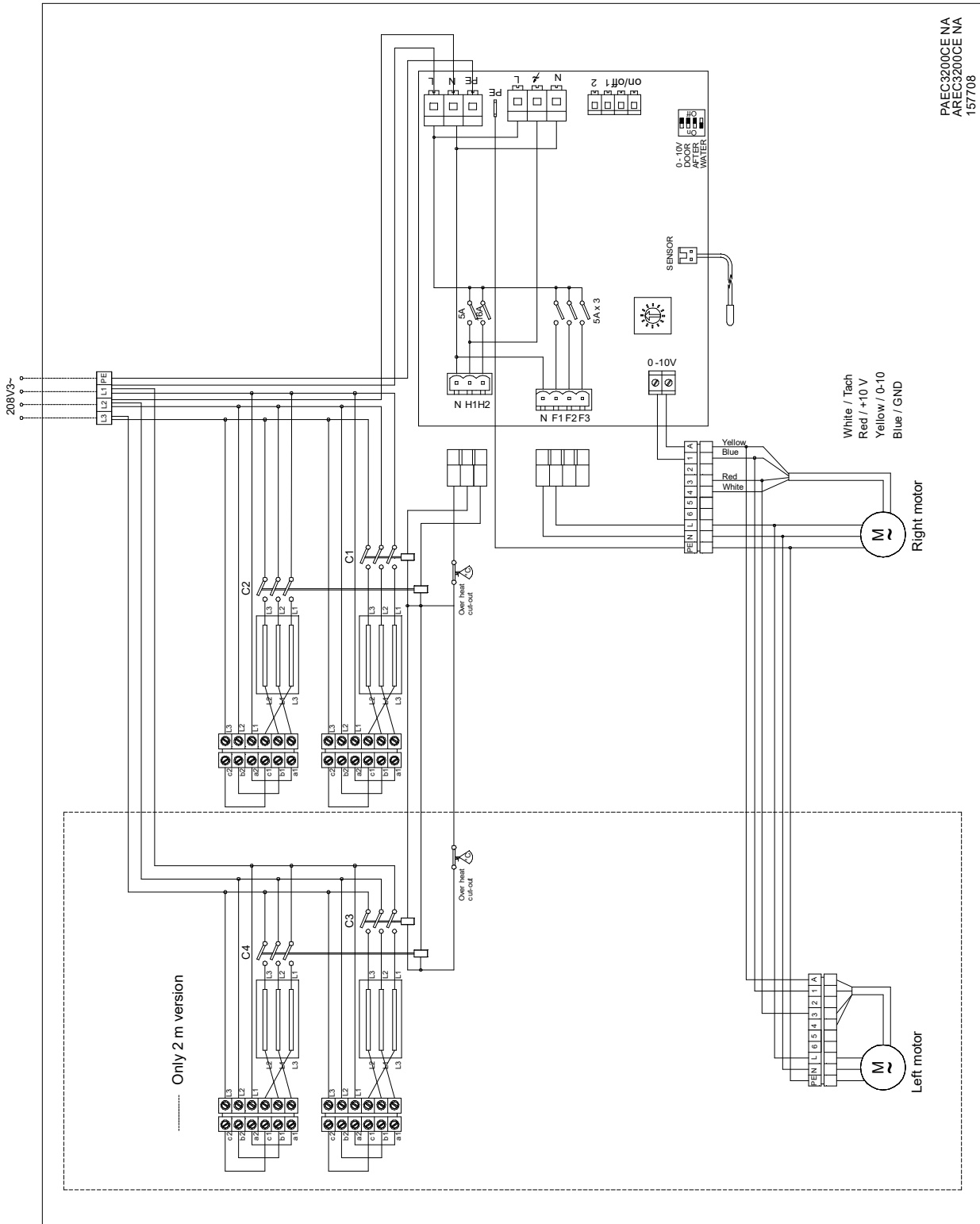

PAEC3200CE NA
AREC3200CE NA
157708

PAEC3200CE-480V/600V

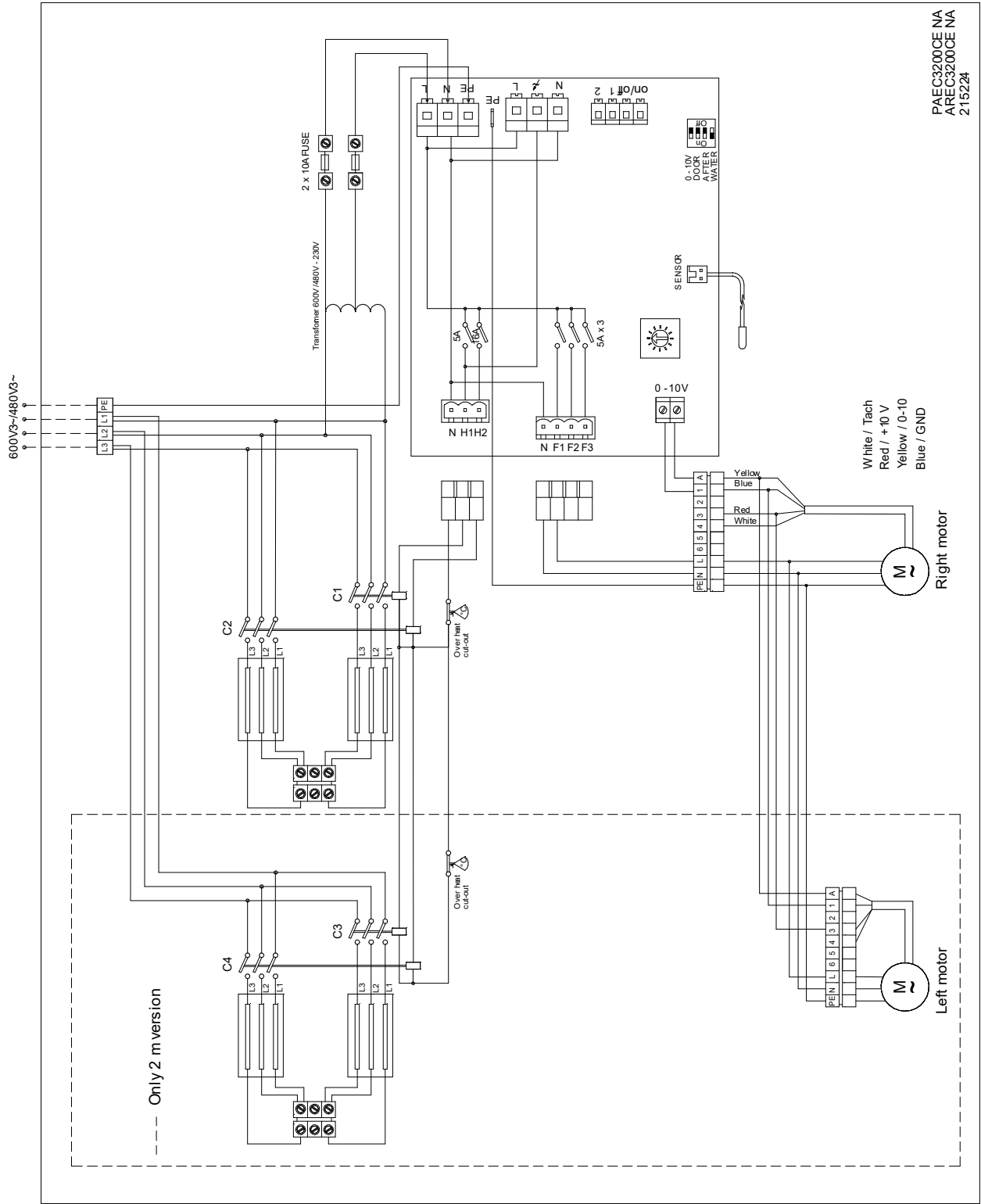

PAEC3200CE NA
AREC3200CE NA
215224

EN

- Read the safety instructions before performing installation and/or maintenance activities on the unit.
- Installation and/or maintenance activities on the unit may only be performed by qualified technical staff.
- The unit shall not be installed and used outdoors or in environments that are aggressive, or potentially explosive. At installation site make sure surrounding environment does not require higher IP classification of the equipment than what is stated on the data label of the unit.
- The unit must be connected in accordance with the applicable local requirements. Make sure that the unit's power supply voltage matches the local mains voltage. The unit's power supply voltage and maximum ratings are displayed on the data label placed on the unit.
- The unit shall be fused according to the table below.
- See also "Safety" on the English pages.

FR

- Veuillez lire les consignes de sécurité avant d'installer l'unité ou d'en effectuer l'entretien.
- L'installation ou l'entretien de l'unité doivent être effectués par un technicien qualifié seulement.
- L'unité ne doit pas être installée et utilisée à l'extérieur ou dans un environnement hostile ou potentiellement explosif. Au site d'installation, veuillez vous assurer que le milieu environnant n'exige pas une classification IP de l'équipement supérieure à ce qui est indiqué sur l'étiquette de données de l'unité.
- L'unité doit être branchée conformément aux exigences locales applicables. Veuillez vous assurer que la tension d'alimentation de l'unité correspond à la tension de secteur locale. La tension d'alimentation de l'unité et les calibres maximums sont indiqués sur l'étiquette de données placée sur l'unité.
- L'unité doit être protégée par un fusible conformément au tableau ci-dessous.
- Voir également la section « Sécurité » dans les pages en français.

ES

- Lea las instrucciones de seguridad antes de realizar trabajos de instalación y/o mantenimiento en la unidad.
- Los trabajos de instalación y/o mantenimiento en la unidad solo deben encomendarse a personal técnico cualificado.
- La unidad no debe instalarse ni utilizarse al aire libre ni en entornos agresivos o potencialmente explosivos. En el lugar de instalación, asegúrese de que el entorno circundante no requiera un equipo con una clasificación IP superior a la que se indica en la etiqueta identificativa de la unidad.
- La unidad debe conectarse de acuerdo a la normativa local vigente. Asegúrese que la tensión de alimentación de la unidad coincida con la tensión de la red eléctrica local. La tensión de alimentación y los valores nominales máximos de la unidad figuran en la etiqueta descriptiva de cada unidad.
- La unidad debe protegerse con fusibles según se indica en la siguiente tabla.
- Consulte también la sección «Seguridad» de la versión en español.

EN: Maximum Amperage on L1, L2 or L3 [A]	EN: Maximum fuse value [A]
FR: Intensité de courant électrique maximale pour L1, L2 ou L3 [A]	FR: Calibre maximum du fusible [A]
ES: Intensidad máxima en L1, L2 o L3 [A]	ES: Valor máximo del fusible [A]
≤ 10A	16A
≤ 15A	20A
≤ 20A	25A
≤ 25A	35A
≤ 35A	50A
≤ 50A	63A
≤ 65A	80A
≤ 80A	100A
≤ 102A	125A

Installation and operating instructions

General Instructions

Read these instructions carefully prior to installation and use. Keep this manual for future reference.

The product may only be used as set out in the assembly and operating instructions. The guarantee is only valid should the product be used in the manner intended and in accordance with the instructions.

Application

PAEC3200C is a compact air curtain with a recommended installation height of up to 3.2 metres/10.5 feet. The air curtain has an integrated control system and can be remotely controlled.

The air curtain is available without heat, with electrical heating and with water heating. Protection class for units with electrical heating: IP20.

Protection class for units without heating and units with water heating: IP21.

Operation

Air is drawn in at the top of the unit and blown downwards shielding the door opening and minimizing heat loss. To achieve the optimum curtain effect the unit must extend the full width of the door opening.

The grille for directing the outlet air is adjustable and is normally angled outwards to achieve the best protection against incoming air.

The efficiency of the air curtain depends on the air temperature, the pressure differential across the doorway and any wind load.

NOTE! Negative pressure in the building considerably reduces the efficiency of the air curtain. The ventilation should therefore be balanced.

Mounting

The air curtain unit is installed horizontally with the supply air grille facing downwards as close to the door as possible. Minimum distance from outlet to floor for electrically heated units is 1800 mm/70.9 in. For other minimum distances, see fig. 4.

Brackets and torx bit are enclosed in the gable end packaging upon delivery.

Mounting with wall brackets (fig. 6)

1. Mount the brackets on the wall, see fig.6A and dimension drawing fig.1. If the wall is uneven the brackets must be compensated for this.
2. Hook on the unit at the lower edge of the brackets. (Fig.6B)
3. Bend the top of the console over the the unit and slide the units screws along the rail into the slots on the consoles. (Fig.6C) When the bracket is bent once, it must be replaced if bent back more than 45 °.
4. Lock the nuts against the brackets. (Fig.6D)

Horizontal mounting on the ceiling

Threaded rods, hanging brackets and ceiling mounting brackets for ceiling mounting are available as accessories, see accessories pages and separate manuals.

Electrical installation

The installation, which should be preceded by an isolator switch with a contact separation of at least 3 mm/0.12 in, should only be wired by a competent electrician and in accordance with the latest edition of IEE wiring regulations. The control system is pre-installed in the air curtain.

Unit without heating or with water heating

Connected via the built-in control board with 1.5 m/4.9 ft cord.

Unit with electrical heating

The electrical connection is made on the top of the unit. See Fig.2. 208V3~/480V3~/600V3~ power supply for heat and control (*1 *2) should be connected to a terminal block in the primary terminal box.

*1 480V3~/ 600V3~ Control supply is transformed via internal transformer to 230V~ and routed through 2x 10A fuses in the primary terminal box.

*2 208V3~ Control supply is connected internally through 2x 10A fuses in the primary terminal box.

The largest cable diameter for the terminal block is AWG6. The cable glands used must meet the protection class requirements. In the distribution board it is to be indicated that "the air curtains can be supplied from more than one connection".

See wiring diagrams.

Control options

Stepless airflow control with door contact/position limit switch

When the door is closed the fan runs at low speed. When the door opens, the fan runs at high speed, set on the remote control or the control panel at the gable end. This control option gives low response time and the best protection.

See Figure 2 and Accessories pages.

Start-up (E)

When the unit is used for the first time or after a long period of non-use, smoke or an odour may result from dust or dirt which has collected on the element. This is completely normal and disappears after a short time.

Connecting the water coil (W)

The installation must be carried out by an authorised installer.

The water coil has copper tubes with aluminium fins and is suitable for connection to a closed water heating system. The heating coil must not be connected to a mains pressure water system or an open water system.

Note that the unit shall be preceded by a regulating valve, see Frico valve kit.

The water coil is connected on top of the unit via steel pipes with DN20 (3/4") terminals, external thread. Flexible hoses are available as accessories, see accessories pages.

The connections to the heating coil must be equipped with shut off valves to allow trouble-free removal. The water coil is equipped with a drain valve. An air valve should be connected at a high point in the pipe system. Air valves are not included.

NOTE: Care must be taken when connecting the pipes. Use a pipe wrench or a similar tool to grip the air curtain connections to prevent straining of the pipes and subsequent water leakage during connection to the water supply pipe-work.

Adjustment of the air curtain and airflow

The direction and speed of the airflow should be adjusted considering the load on the opening. Pressure forces affect the airstream and force it inwards towards the premises (when the premises are heated and the outdoor air is cold).

The airstream should, therefore, be directed outwards to withstand the load. Generally speaking, the higher the load, the greater the angle required.

Basic setting fan speed

The fan speed when the door is open is set using the control. Note that the airflow direction and the fan speed may need fine adjustment depending on the loading of the door.

Filter (W)

The water coil is protected against dirt and blockage by an internal air filter which covers the coil face. In environments where the filter requires frequent cleaning, it is advisable to use an external intake filter (see accessories pages), which provides easier maintenance, since the unit does not need to be opened. When an external filter is used, the internal filter is removed.

Service, repairs and maintenance

For all service, repair and maintenance first carry out the following:

1. Disconnect the power supply.
2. The front hatch is removed by removing the screws on the top of the unit and then detach the bent edge at the bottom. (Fig.3)
3. After the service, repair and maintenance reattach the front hatch. Place the hatch at the lower edge with the bent edge and fasten on top with screws.

Note that when carrying out work where the end is removed, the outlet grille also detaches.

Maintenance

Unit with water heating

The appliance filter should be cleaned regularly to ensure the air curtain effect and heat emission from the device. How often depends on local circumstances. A clogged filter is not a risk, but the appliance function can fail.

1. Disconnect the power supply.
2. The front hatch is removed by removing the screws on the top of the unit and then detach the bent edge at the bottom. (Fig.3)
3. Remove the filter and vacuum clean or wash it. If the filter is clogged or damaged, it may need to be changed.

All units

Since fan motors and other components are maintenance-free, no maintenance other than cleaning is necessary. The level of cleaning can vary depending on local conditions. Undertake cleaning at least twice a year. Inlet and exhaust grilles, impeller and elements can be vacuum cleaned or wiped using a damp cloth. Use a brush when vacuuming to prevent damaging sensitive parts. Avoid the use of strong alkaline or acidic cleaning agents.

Overheating

The air curtain unit with electrical heating is equipped with an overheat protection. If it is deployed due to overheating, reset as follows:

1. Disconnect the power supply with the isolator switch.
2. Determine the cause of overheating and rectify the fault.
3. Remove the front hatch.
4. Press the red button located inside the air curtain unit, at the inner gable of the terminal box.
5. Reattach the front hatch and connect the unit again.

All motors are equipped with an integral thermal safety cut-out. This will operate, stopping the air curtain should the motor temperature rise too high. The cut-out will automatically reset when the motor temperature has returned to within the motor's operating limits.

Temperature control

See control pages.

Replacing motor or impeller

1. Remove the front.
2. Remove gable end.
3. Remove the screw between motor and fan.
4. Disconnect the cables to the motor.
5. Remove the screws securing the motor and lift it out together with the impeller.
6. Install the new motor and/or the new impeller as above in reverse order.

Replacing heating elements/heating package (E)

1. Mark and disconnect the cables to the heating elements/package.
2. Remove the mounting screws securing the heating elements/package in the unit and lift the heating elements/package out.
3. Install the new heating elements/package in reverse order to the above.

Replacing the water coil (W)

1. Shut off the water supply to the unit.
2. Disconnect the connections to the water coil.
3. Detach the plastic ends.
4. Detach the intake grille by drilling out the rivet(s).
5. Remove the mounting screws securing the coil in the unit and lift out.
6. Install the new coil in reverse order to the above.

Draining the water coil (W)

The drain valve is on the underside of the coil on the connector side. It can be accessed via the front hatch.

Troubleshooting

If the fans are not running or do not perform properly, check the following:

- The functions and settings of the built-in control system.
- That the intake grille/filter is not dirty.

If there is no heat, check the following:

- The functions, internal sensor and settings of the built-in control system.

For units with electrical heating, also check the following:

- Power supply to electric heater coil; check fuses and circuit-breaker (if any).
- That the overheat protection has not been deployed.

For units with a water coil, also check the following:

- That the water coil is air free.
- That there is sufficient water flow and pressure.
- That incoming water is heated adequately.

If the fault cannot be rectified, please contact a qualified service technician.

Residual current circuit breaker (E)

When the installation is protected by means of a residual current circuit breaker, which trips when the appliance is connected, this may be due to moisture in the heating element. When an appliance containing a heater element has not been used for a long period or stored in a damp environment, moisture can enter the element.

This should not be seen as a fault, but is simply rectified by connecting the appliance to the main supply via a socket without a safety cut-out so that the moisture can be eliminated from the element. The drying time can vary from a few hours to a few days. As a preventive measure, the unit should occasionally be run for a short time when it is not being used for extended periods of time.

Packaging

Packaging materials are chosen with consideration to the environment and are therefore recyclable.

Handling of product at end of working life

This product may contain substances necessary for the functionality of the product but potentially dangerous for the environment. The product should not be disposed of mixed with general household waste but delivered to a designated collection point for environmental recycling. Please contact the local authority for further details of your nearest designated collection point.

Safety

- *For all installations of electrically heated products a residual current circuit breaker 300 mA for fire protection should be used.*
- *Keep the areas around the air intake and exhaust grilles free from possible obstructions!*
- *The unit must not be fully or partially covered as overheating can result in a fire risk!*
- *Lifting equipment must be used to lift the unit.*
- *This appliance can be used by children aged from 8 years and above and persons with reduced physical, sensory or mental capabilities or lack of experience and knowledge if they have been given supervision or instruction concerning use of the appliance in a safe way and understand the hazards involved. Children shall not play with the appliance. Cleaning and user maintenance shall not be made by children without supervision.*
- *Children of less than 3 years should be kept away unless continuously supervised.*
- *Children aged from 3 years and less than 8 years shall only switch on/off the appliance provided that it has been placed or installed in its intended normal operating position and they have been given supervision or instruction concerning use of the appliance in a safe way and understand the hazards involved.*
- *Children aged from 3 years and less than 8 years shall not plug in, regulate and clean the appliance or perform user maintenance.*

CAUTION — Some parts of this product can become very hot and cause burns. Particular attention has to be given where children and vulnerable people are present.

Control

The air curtain has an integrated control system and can be remotely controlled.

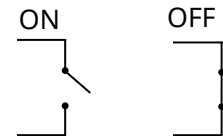
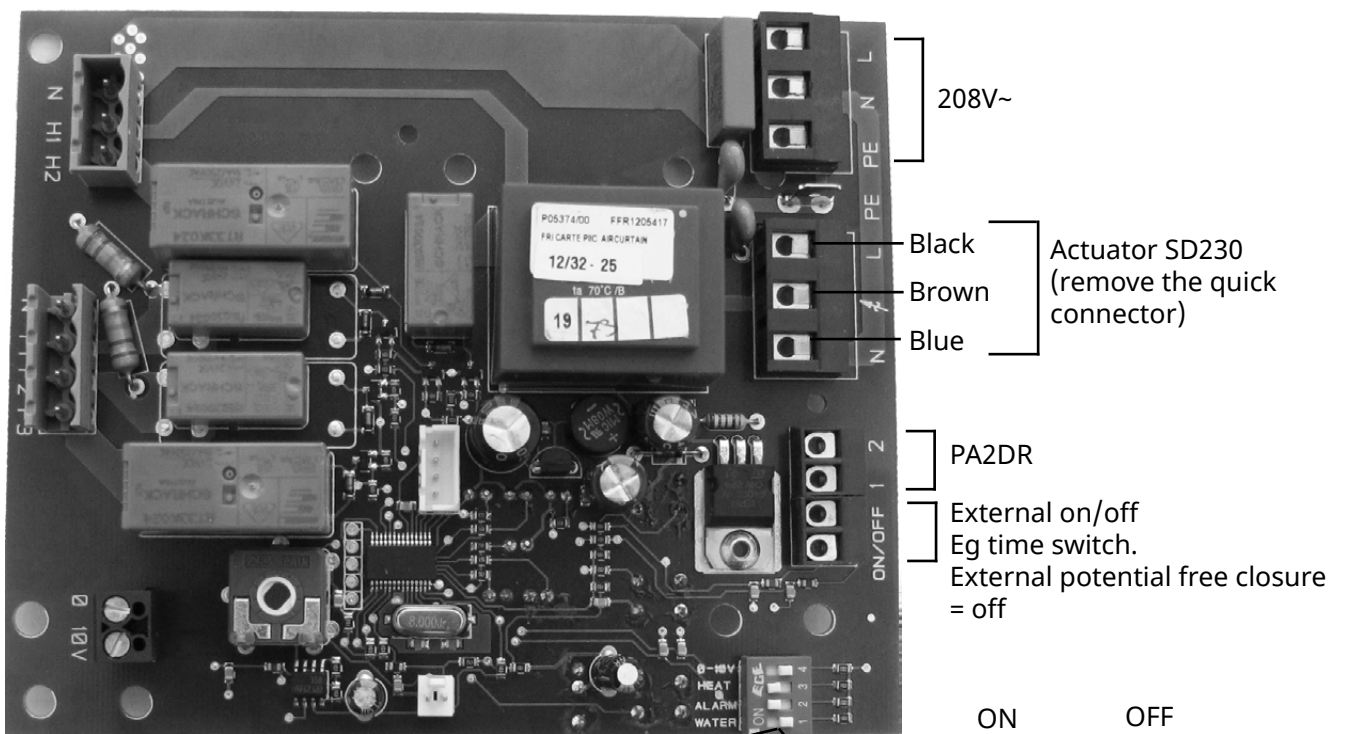
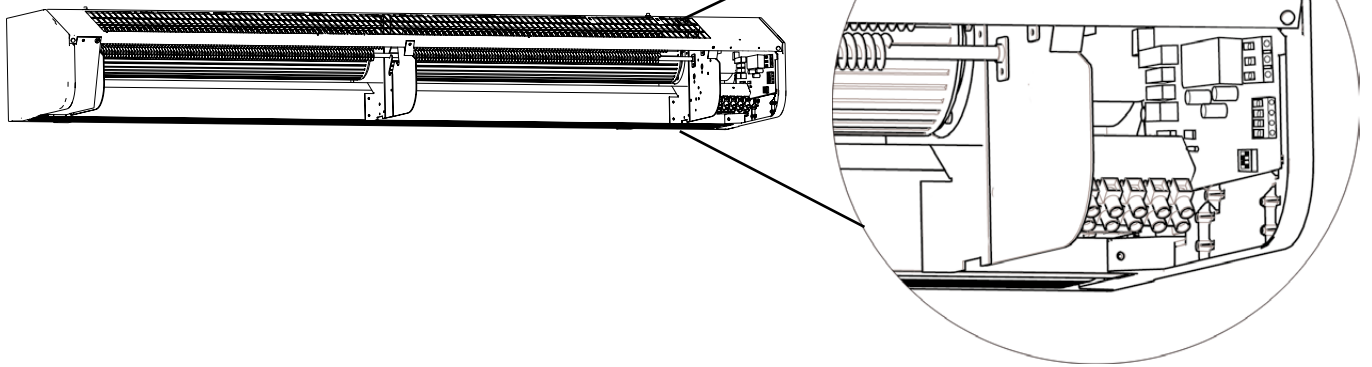

0-10V	<input type="checkbox"/>	4
HEAT	<input type="checkbox"/>	3
ALARM	<input type="checkbox"/>	2
WATER	<input type="checkbox"/>	1

ON



Factory setting dip-switches - Unit without heating or with electrical heating

Dip-switch 3 is used for PA2DR.

0-10V	<input type="checkbox"/>	4
HEAT	<input checked="" type="checkbox"/>	3
ALARM	<input type="checkbox"/>	2
WATER	<input type="checkbox"/>	1

ON



Factory setting dip-switches - Unit with water heating

Dip-switch 3 is used for PA2DR.

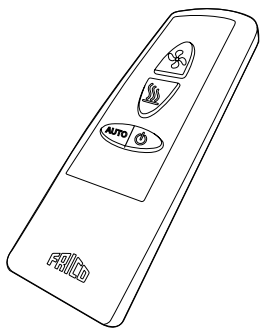
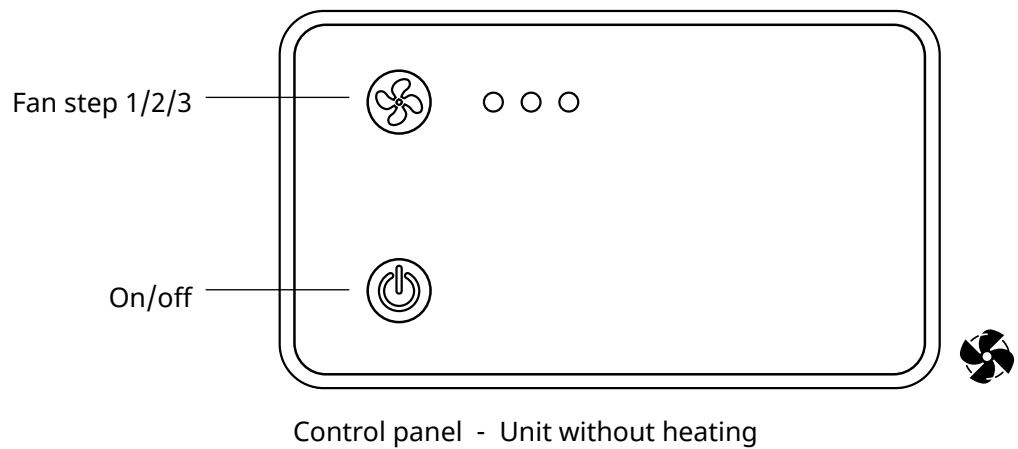
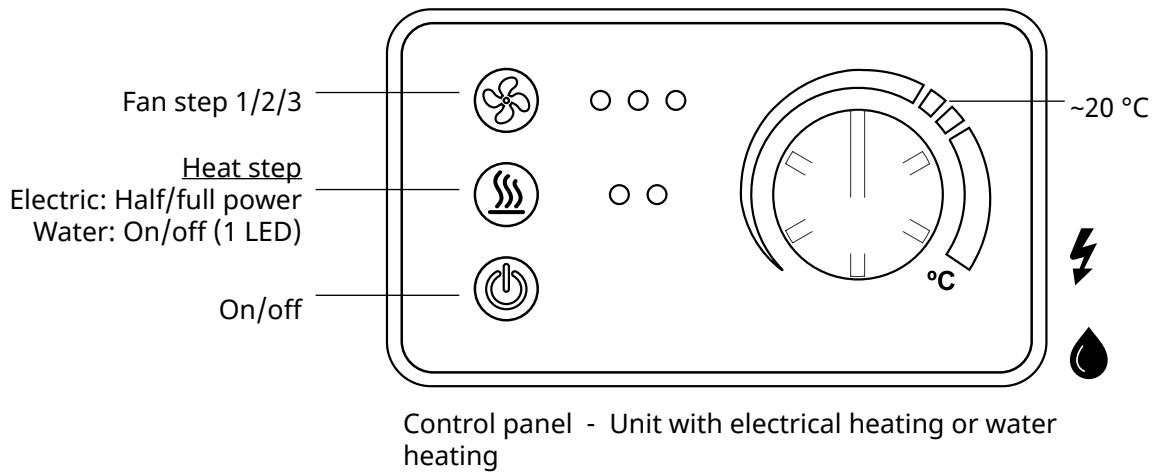

Remote control - on/off, fan steps and heating steps

Functional test

Functional test is started using the remote control.

Push



and



in 5 seconds

Fan and heatings steps are tested in 10-second intervals which is indicated by lighted LEDs. When the test is completed, all LEDs will flash for 30 seconds.

Temperature control

If the temperature exceeds 50 °C, the fan runs at full speed for 2 minutes to vent out the heat, if the temperature rises above 50 °C again during the following 5 minutes overheating alarm is deployed. The red LEDs flash and all the buttons are locked.

1. Disconnect the power supply with the isolator switch.
2. Determine the cause of overheating and rectify the fault.
3. Reconnect the unit.



**UK
CA**

Main office

Frico AB
Industrivägen 41
SE-433 61 Sävedalen
Sweden

Tel: +46 31 336 86 00
mailbox@frico.se
www.frico.net

**For latest updated information and information
about your local contact: www.frico.net**

CE

Original instructions
AREC3200C

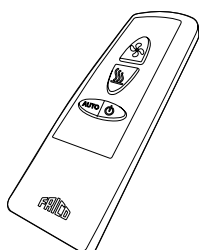
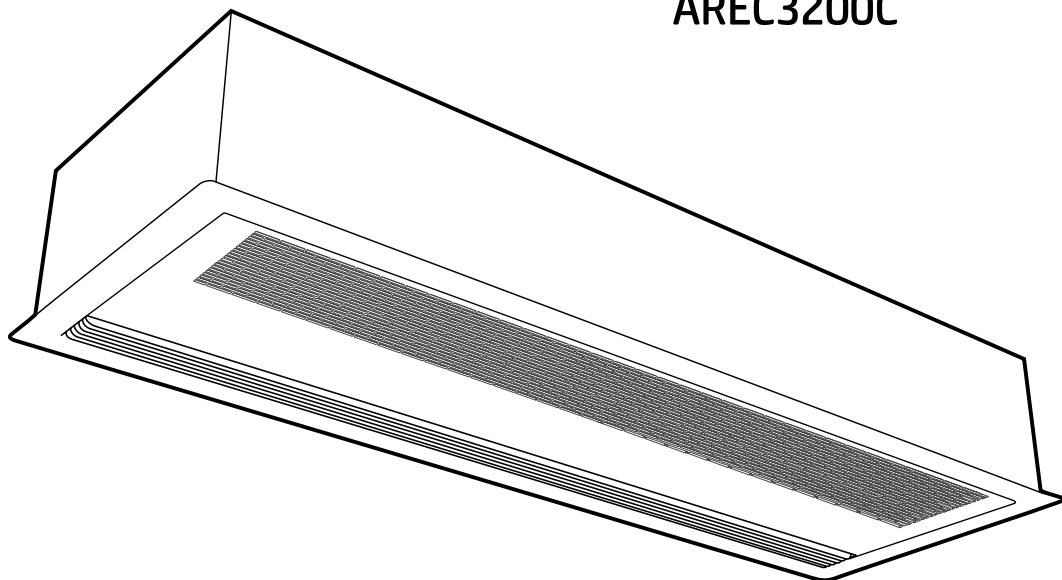

EN 19

FR 25

ES 34



Frico AB certifies that the AREC3200CA, AREC3200CE and AREC3200CW air curtains shown herein are licensed to bear the AMCA Seal. The ratings shown are based on tests and procedures performed in accordance with AMCA Publication 211 and AMCA Publication 311 and comply with the requirements of the AMCA Certified Ratings Program. The AMCA Certified Ratings Seal applies to airflow rate, average outlet velocity, outlet velocity uniformity, velocity projection and power rating at free delivery only.

AREC3200C

Metric chart

☼ Ambient, no heat - AREC3200CA (IP21)

Type	Output [kW]	Airflow* ¹ [m ³ /h]	Sound power* ² [dB(A)]	Motor power [W]	Voltage motor [V]	Amperage motor [A]	Weight [kg]
AREC3210CA-NA	0	1630	72	127	208V~	0.8	29
AREC3215CA-NA	0	2300	73	148	208V~	0.9	40
AREC3220CA-NA	0	3250	74	254	208V~	1.5	55

⚡ Electrical heat - AREC3200CE (IP20)

Type	Output steps [kW]	Airflow* ¹ [m ³ /h]	Sound power* ² [dB(A)]	FLA (full load amperage)* ³ [A]	Motor power [W]	Amperage motor [A]	Voltage [V] Amperage [A] (heat)	Weight [kg]
AREC3210CE07-208VNA	4/7	1630	72	21	127	0.8	208V3~/20	31
AREC3215CE10-208VNA	7/10	2300	73	29	148	0.9	208V3~/28	42
AREC3220CE13-208VNA	8/13	3250	74	39	254	1.5	208V3~/36	59
AREC3210CE08-480VNA	5/8	1630	72	11	127	0.8	480V3~/10	31
AREC3215CE12-480VNA	8/12	2300	73	16	148	0.9	480V3~/15	42
AREC3220CE16-480VNA	10/16	3250	74	21	254	1.5	480V3~/20	59
AREC3210CE08-600VNA	5/8	1630	72	9	127	0.8	600V3~/8	31
AREC3215CE12-600VNA	8/12	2300	73	13	148	0.9	600V3~/12	42
AREC3220CE16-600VNA	10/16	3250	74	17	254	1.5	600V3~/16	59

💧 Water heat - AREC3200CW (IP21)

Type	Output* ⁴ [kW]	Airflow* ¹ [m ³ /h]	Sound power* ² [dB(A)]	Motor power [W]	Voltage motor [V]	Amperage motor [A]	Water volume [l]	Weight [kg]
AREC3210CW-NA	8	1300	72	127	208V~	0.8	1.3	30
AREC3215CW-NA	14	2050	73	148	208V~	0.9	2.1	41
AREC3220CW-NA	19	2550	74	254	208V~	1.5	2.7	56

*¹) Highest airflow of totally 3 fan steps.

*²) Values shown are for total sound power levels for Installation Type A: free inlet, free outlet. The Sound power level ratings shown are in decibels, referred to 10-12 watts, calculated per AMCA Standard 301.

*³) FLA: total amperage for motor and heat.

*⁴) Applicable at water temperature 60/40 °C, air temperature, in +18 °C.

Above table is valid for 208V/1ph/60Hz. Also approved for 230V/1ph/60Hz. Product performance for 230V/1ph/60Hz will differ from stated data.

Protection class for units with electrical heating: IP20.

Protection class for units without heating and units with water heating: IP21.

CE compliant.

AREC3200C

Type	Nozzle depth and width [mm]	Max velocity at nozzle [m/s]	Outlet velocity [m/s]	Outlet velocity uniformity [%]
AREC3210CA/E/W-NA	70x970	10.97	9.50	78
AREC3215CA/E/W-NA	70x1485	10.25	9.40	83
AREC3220CA/E/W-NA	70x2000	10.97	9.50	78

Velocity projection: Model AREC3210CE/A-NA

Distance from nozzle [mm]	70	500	1000
Core velocity [m/s]	9.5	6.68	4.51
Uniformity [%]	78	82	81

Velocity projection: Model AREC3210CW-NA

Distance from Nozzle [mm]	70	500	1000
Core Velocity [m/s]	8	5.87	4.17
Uniformity [%]	79	87	88



Frico AB certifies that the AREC3200CA, AREC3200CE and AREC3200CW air curtains shown herein are licensed to bear the AMCA Seal. The ratings shown are based on tests and procedures performed in accordance with AMCA Publication 211 and AMCA Publication 311 and comply with the requirements of the AMCA Certified Ratings Program. The AMCA Certified Ratings Seal applies to airflow rate, average outlet velocity, outlet velocity uniformity, velocity projection and power rating at free delivery only.

AREC3200C

Imperial chart

☼ Ambient, no heat - AREC3200CA (IP21)

Type	Output [MBH]	Airflow* ¹ [cfm]	Sound power* ² [dB(A)]	Motor power [W]	Voltage motor [V]	Amperage motor [A]	Weight [lb]
AREC3210CA-NA	0	950	72	127	208V~	0.8	64
AREC3215CA-NA	0	1350	73	148	208V~	0.9	87
AREC3220CA-NA	0	1900	74	254	208V~	1.5	121

⚡ Electrical heat - AREC3200CE (IP20)

Type	Output steps [MBH]	Airflow* ¹ [cfm]	Sound power* ² [dB(A)]	FLA (full load amperage)* ³ [A]	Motor power [W]	Amperage motor [A]	Voltage [V] Amperage [A] (heat)	Weight [lb]
AREC3210CE07-208VNA	14/24	950	72	21	127	0.8	208V3~/20	68
AREC3215CE10-208VNA	24/34	1350	73	29	148	0.9	208V3~/28	91
AREC3220CE13-208VNA	27/44	1900	74	39	254	1.5	208V3~/36	130
AREC3210CE08-480VNA	17/27	950	72	11	127	0.8	480V3~/10	68
AREC3215CE12-480VNA	27/41	1350	73	16	148	0.9	480V3~/15	91
AREC3220CE16-480VNA	34/55	1900	74	21	254	1.5	480V3~/20	130
AREC3210CE08-600VNA	17/27	950	72	9	127	0.8	600V3~/8	68
AREC3215CE12-600VNA	27/41	1350	73	13	148	0.9	600V3~/12	91
AREC3220CE16-600VNA	34/55	1900	74	17	254	1.5	600V3~/16	130

💧 Water heat - AREC3200CW (IP21)

Type	Output* ⁴ [MBH]	Airflow* ¹ [cfm]	Sound power* ² [dB(A)]	Motor power [W]	Voltage motor [V]	Amperage motor [A]	Water volume [US gal]	Weight [lb]
AREC3210CW-NA	27	750	72	127	208V~	0.8	0.34	65
AREC3215CW-NA	48	1200	73	148	208V~	0.9	0.55	90
AREC3220CW-NA	65	1500	74	254	208V~	1.5	0.71	123

*¹) Highest airflow of totally 3 fan steps.

*²) Values shown are for total sound power levels for Installation Type A: free inlet, free outlet. The Sound power level ratings shown are in decibels, referred to 10-12 watts, calculated per AMCA Standard 301.

*³) FLA: total amperage for motor and heat.

*⁴) Applicable at water temperature 140/104F, air temperature, in +64F.

Above table is valid for 208V/1ph/60Hz. Also approved for 230V/1ph/60Hz. Product performance for 230V/1ph/60Hz will differ from stated data.

Protection class for units with electrical heating: IP20.

Protection class for units without heating and units with water heating: IP21.

CE compliant.

AREC3200C

Type	Nozzle depth and width [in]	Max velocity at nozzle [fpm]	Outlet velocity [fpm]	Outlet velocity uniformity [%]
AREC3210CA/E/W-NA	2.8x38.2	2159	1870	78
AREC3215CA/E/W-NA	2.8x58.5	2018	1850	83
AREC3220CA/E/W-NA	2.8x78.7	2159	1870	78

Velocity projection: Model AREC3210CE/A-NA

Distance from Nozzle [in]	2.7	20	40
Core Velocity [fpm]	1870	1314	887
Uniformity [%]	78	82	81

Velocity projection: Model AREC3210CW-NA

Distance from Nozzle [in]	2.7	20	40
Core Velocity [fpm]	1574	1155	820
Uniformity [%]	79	87	88



Frico AB certifies that the AREC3200CA, AREC3200CE and AREC3200CW air curtains shown herein are licensed to bear the AMCA Seal. The ratings shown are based on tests and procedures performed in accordance with AMCA Publication 211 and AMCA Publication 311 and comply with the requirements of the AMCA Certified Ratings Program. The AMCA Certified Ratings Seal applies to airflow rate, average outlet velocity, outlet velocity uniformity, velocity projection and power rating at free delivery only.

Output charts water AREC3200C

Metric chart

			Supply water temperature: 80 °C Room temperature: +18 °C Outlet air temperature: +35 °C*1				Water temperature: 80/60 °C Room temperature: +18 °C			
Type	Fan position	Airflow	Output	Return water temp.	Water flow	Pressure drop	Output*2	Outlet air temp.	Water flow	Pressure drop
		[m³/h]	[kW]	[°C]	[l/s]	[kPa]	[kW]	[°C]	[l/s]	[kPa]
AREC3210CW-NA	max	1300	8.8	35	0.05	2.4	14.1	46	0.17	23.7
AREC3215CW-NA	max	2050	15.2	33	0.08	8.5	24.5	46	0.30	92.3
AREC3220CW-NA	max	2550	18.2	32	0.09	4.9	30.5	47	0.37	60.7

			Supply water temperature: 60 °C Room temperature: +18 °C Outlet air temperature: +35 °C*1				Water temperature: 60/40 °C Room temperature: +18 °C			
Type	Fan position	Airflow	Output	Return water temp.	Water flow	Pressure drop	Output*2	Outlet air temp.	Water flow	Pressure drop
		[m³/h]	[kW]	[°C]	[l/s]	[kPa]	[kW]	[°C]	[l/s]	[kPa]
AREC3210CW-NA	max	1300	8.8	43	0.12	14.0	8.2	34	0.10	9.2
AREC3215CW-NA	max	2050	15.2	42	0.20	48.5	14.4	34	0.17	37.2
AREC3220CW-NA	max	2550	18.2	41	0.23	27.5	17.9	35	0.22	24.1

*1) Recommended outlet air temperature for good comfort and optimized output.

*2) Nominal output at given supply and return water temperature.

Imperial chart

			Supply water temperature: 176 °F Room temperature: +64 °F Outlet air temperature: +95 °F*1				Water temperature: 176/140 °F Room temperature: +64 °F			
Type	Fan position	Airflow	Output	Return water temp.	Water flow	Pressure drop	Output*2	Outlet air temp.	Water flow	Pressure drop
		[cfm]	[MBH]	[°F]	[US gal/h]	[kPa]	[MBH]	[°F]	[US gal/h]	[kPa]
AREC3210CW-NA	max	750	30.0	95	47.6	2.4	48.1	115	161.7	23.7
AREC3215CW-NA	max	1200	51.9	91	76.1	8.5	83.6	115	285.3	92.3
AREC3220CW-NA	max	1500	62.1	90	85.6	4.9	104.1	117	351.9	60.7

			Supply water temperature: 140 °F Room temperature: +64 °F Outlet air temperature: +95 °F*1				Water temperature: 140/104 °F Room temperature: +64 °F			
Type	Fan position	Airflow	Output	Return water temp.	Water flow	Pressure drop	Output*2	Outlet air temp.	Water flow	Pressure drop
		[cfm]	[MBH]	[°F]	[US gal/h]	[kPa]	[MBH]	[°F]	[US gal/h]	[kPa]
AREC3210CW-NA	max	750	30.0	109	114.1	14.0	28.0	93	95.1	9.2
AREC3215CW-NA	max	1200	51.9	108	190.2	48.5	49.1	93	161.7	37.2
AREC3220CW-NA	max	1500	62.1	106	218.8	27.5	61.1	95	209.2	24.1

*1) Recommended outlet air temperature for good comfort and optimized output.

*2) Nominal output at given supply and return water temperature.



The introduction pages consist mainly of pictures. For translation of the English texts used, see the respective language pages.



Les pages de présentation contiennent principalement des images. Pour la traduction des textes en anglais, consultez la page correspondante à la langue souhaitée.



Las páginas introductorias contienen básicamente imágenes. Consulte la traducción de los textos en inglés que las acompañan en las páginas del idioma correspondiente.

AREC3200C

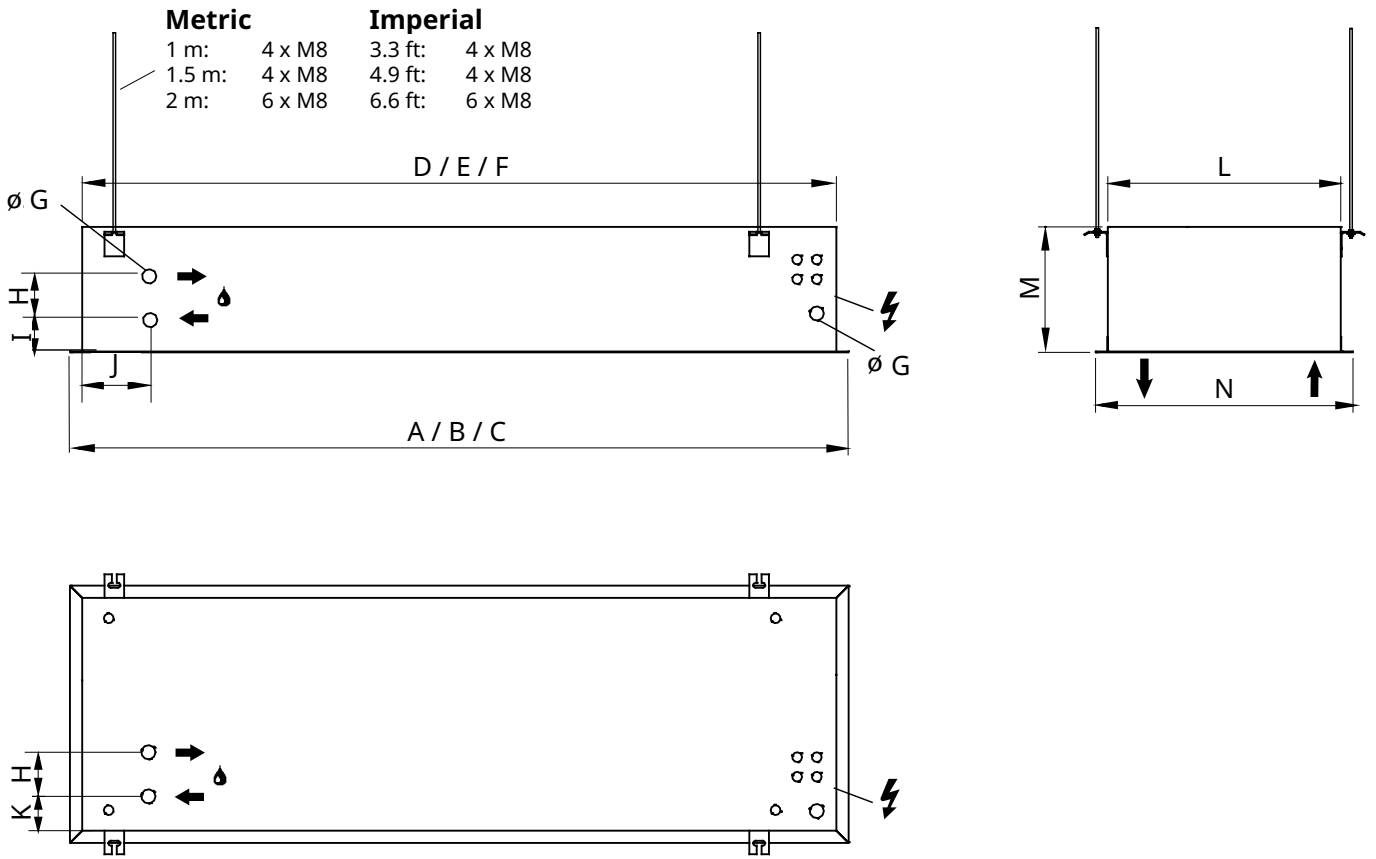

Ref	Metric [mm]	Imperial [in]	Product type
A	1078	43.12	AREC3210Cx
B	1588	63.52	AREC3215Cx
C	2078	83.12	AREC3220Cx
D	1028	41.12	AREC3210Cx
E	1538	61.52	AREC3215Cx
F	2028	81.12	AREC3220Cx
G	29	1.16	
H	90	3.60	
I	51	2.04	
J	135	5.40	
K	70	2.80	
L	475	19.00	
M	256	10.24	
N	525	21.00	

Mounting on threaded bars outside the unit

Front view

AREC3210Cx/AREC3215Cx

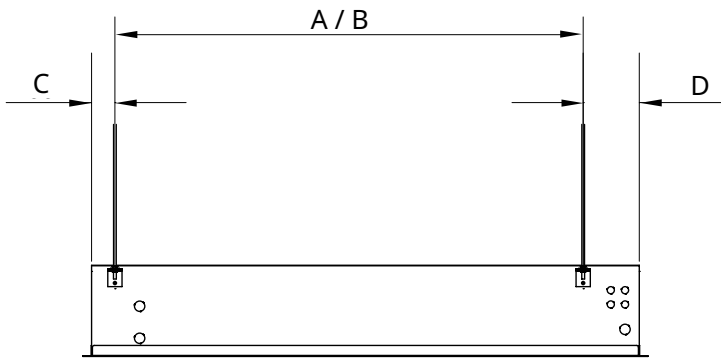

Side view

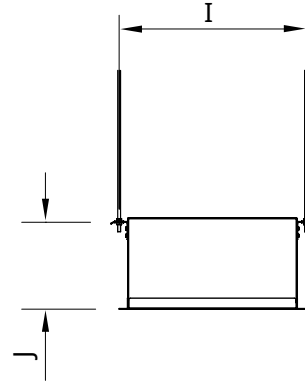

AREC3220Cx

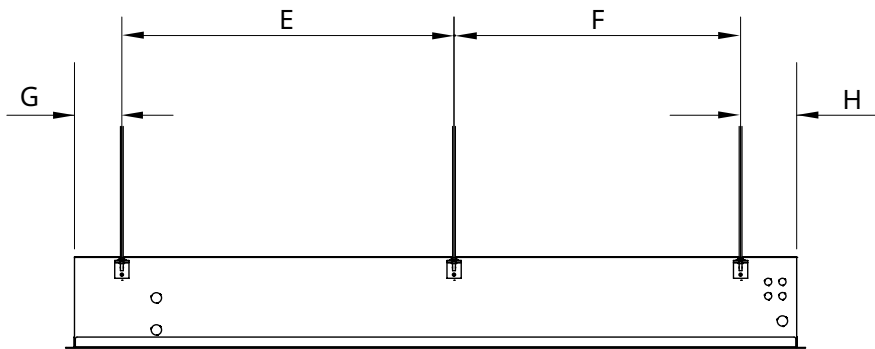

Ref	Metric [mm]	Imperial [in]	Product type
A	805	32.20	AREC3210Cx
B	1315	52.60	AREC3215Cx
C	66	2.64	
D	157	6.28	
E	933	37.32	
F	805	32.20	
G	134	5.36	
H	156	6.24	
I	525	21.00	
J	244	9.76	

Mounting on threaded bars outside the unit

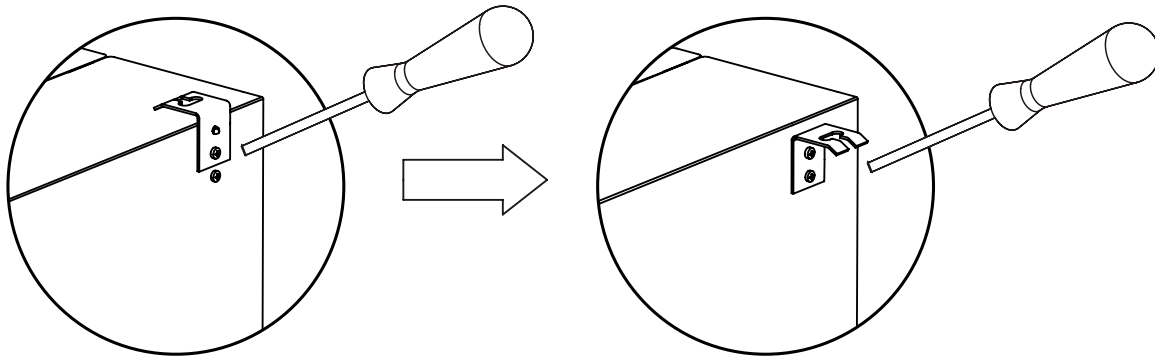

Fig. 1a: Mounting brackets on delivery.

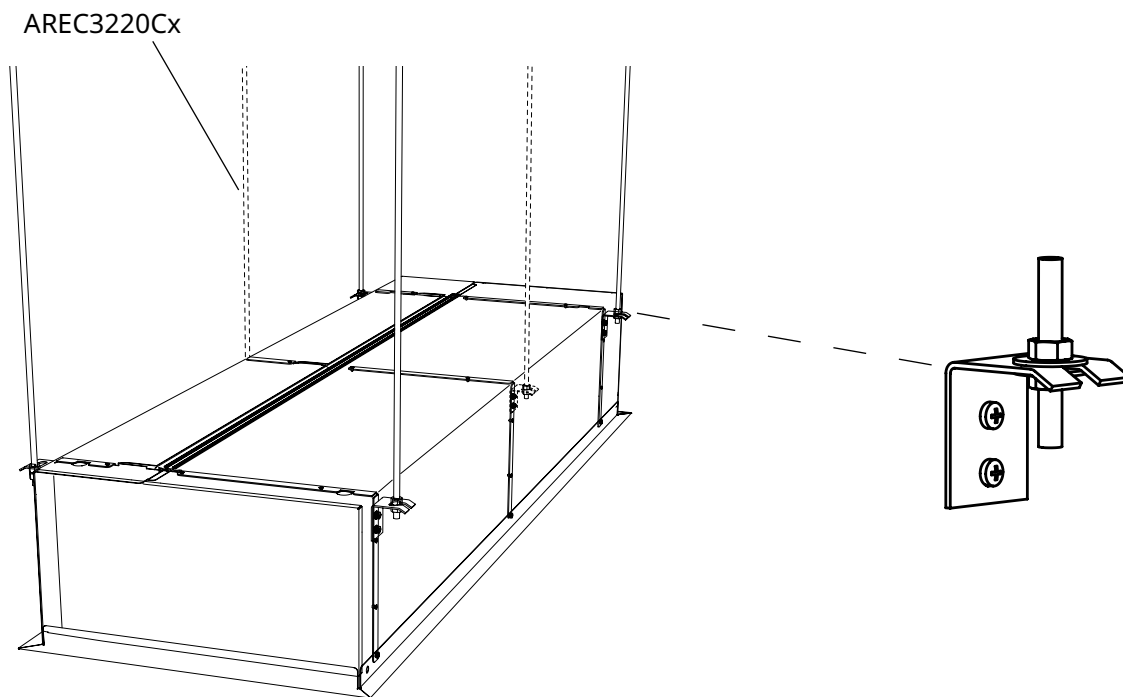
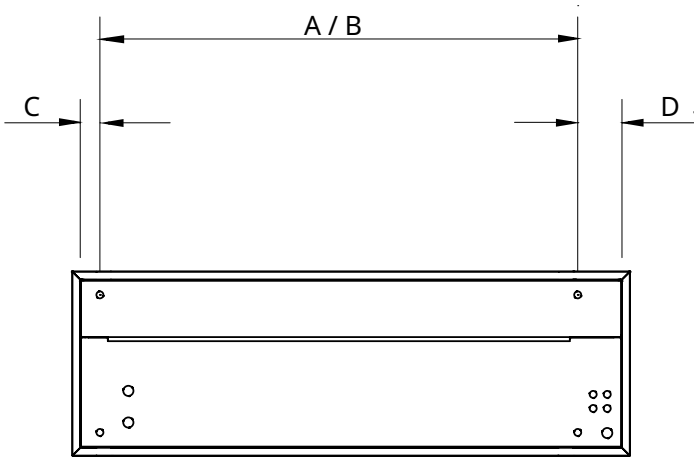

Fig. 1b. Mounting on threaded bars outside the unit.

Mounting on threaded bars inside the unit

Top view

AREC3210Cx/ AREC3215Cx



Side view

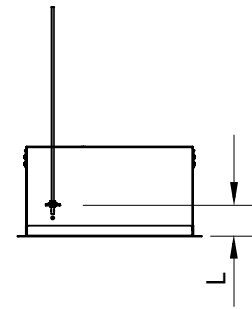

AREC3220Cx

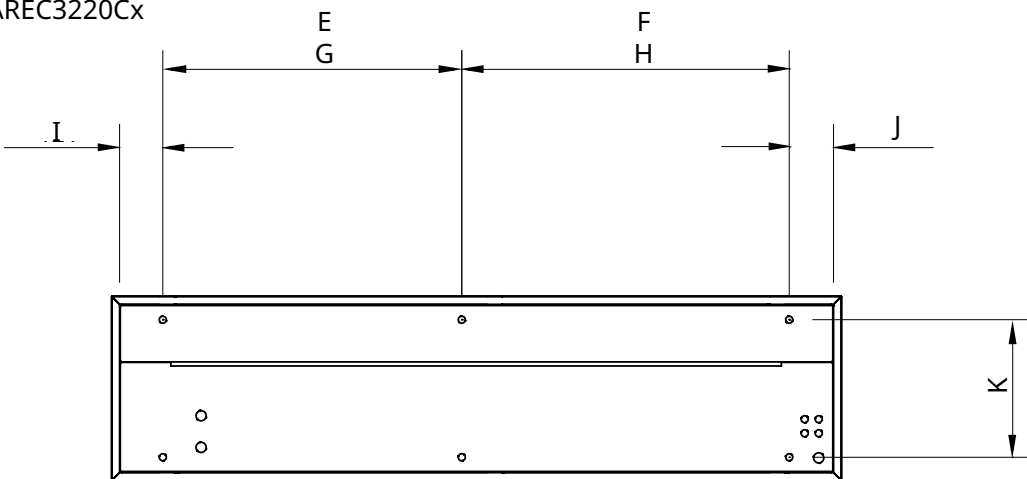

Ref	Metric [mm]	Imperial [in]	Product type
A	850	34.00	AREC3210Cx
B	1360	54.40	AREC3215Cx
C	54	2.16	
D	124	4.96	
E	851	34.04	AREC3220CE/A
F	932	37.28	AREC3220CE/A
G	935	37.4	AREC3220CW
H	848	33.92	AREC3220CW
I	121	4.84	
J	124	4.96	
K	392	15.68	
L	88	3.52	

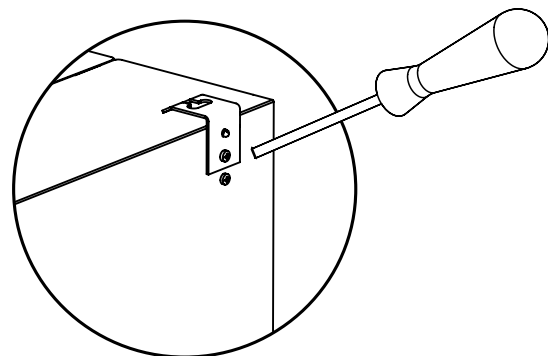

Fig. 2a: Mounting brackets on delivery.

Mounting on threaded bars inside the unit

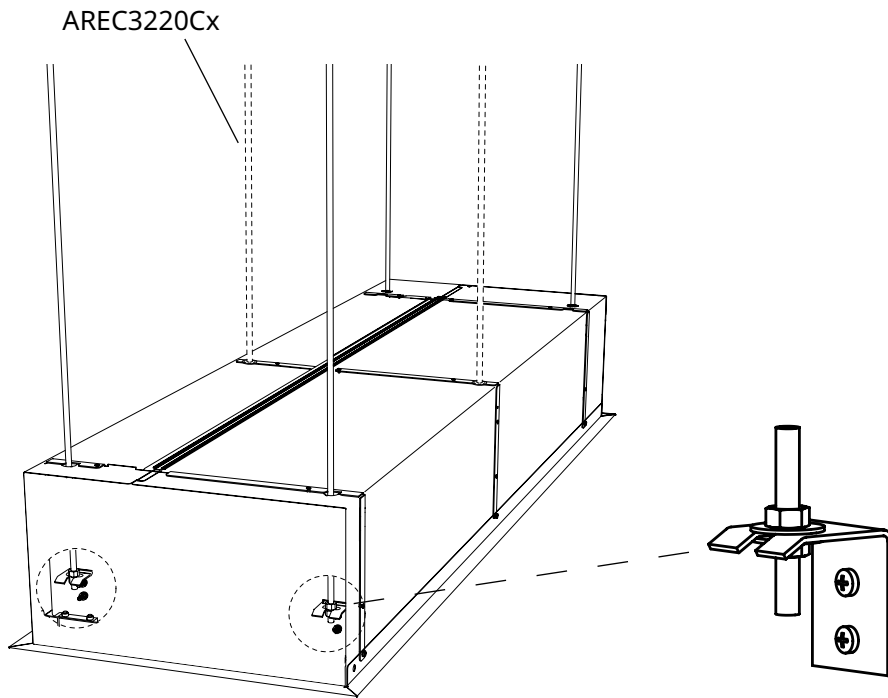

Fig. 2b. Mounting on threaded bars inside the unit.

AREC3210Cx, AREC3215Cx 4x
AREC3220Cx 6x

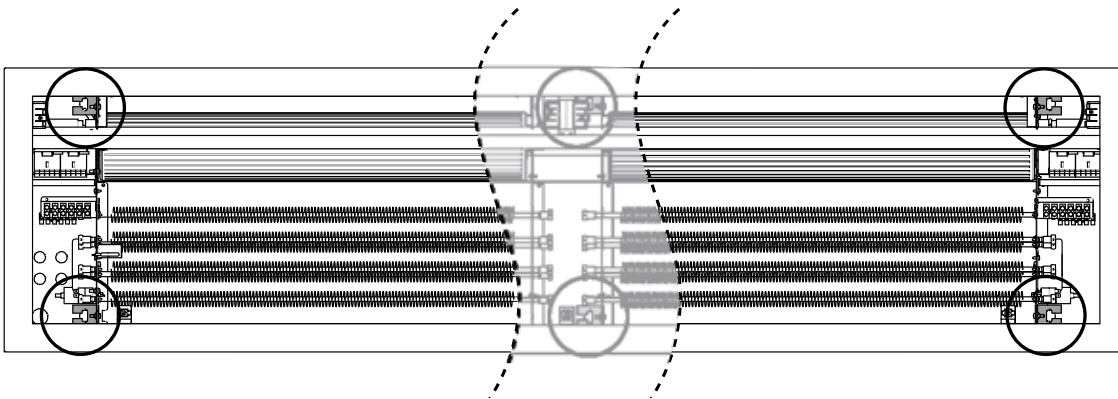

Fig. 2c. Location of the mounting brackets on the inside of the unit.

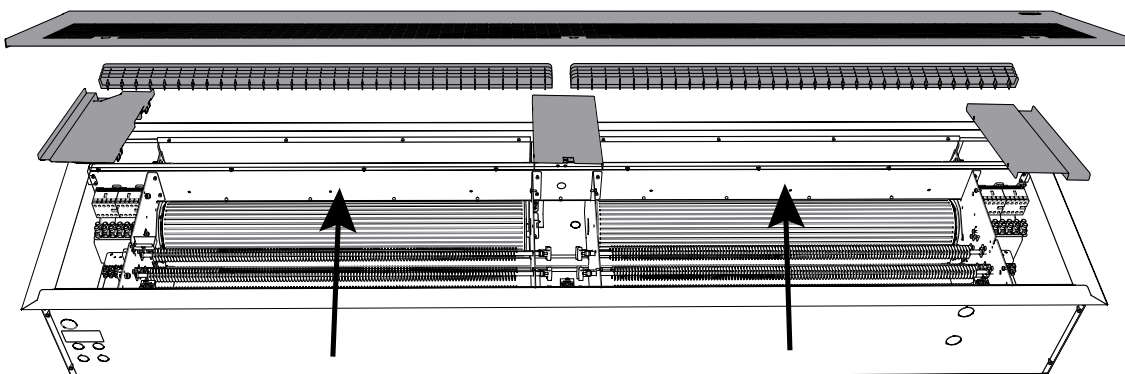

Fig. 2d. In order to mount the brackets, remove the service hatch, outlet grille and covering plates.

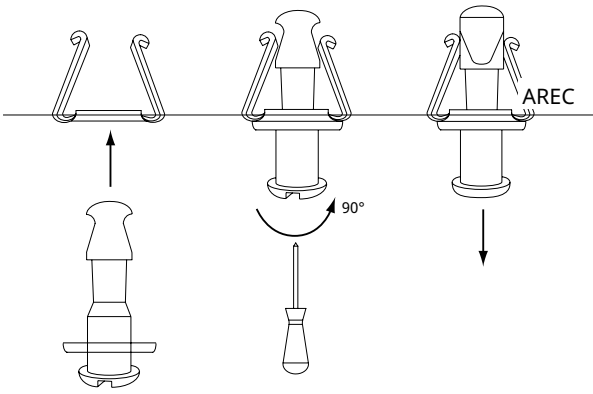

Fig. 3a: Snap fixings

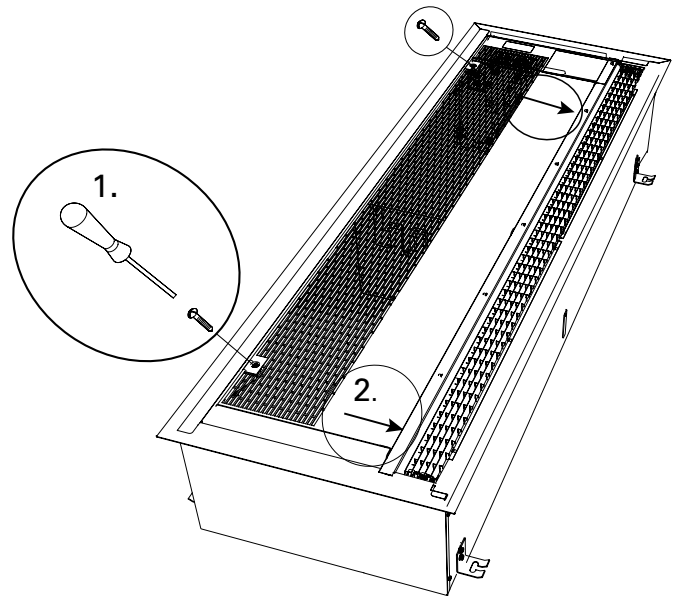

Fig. 3b: Open the unit.

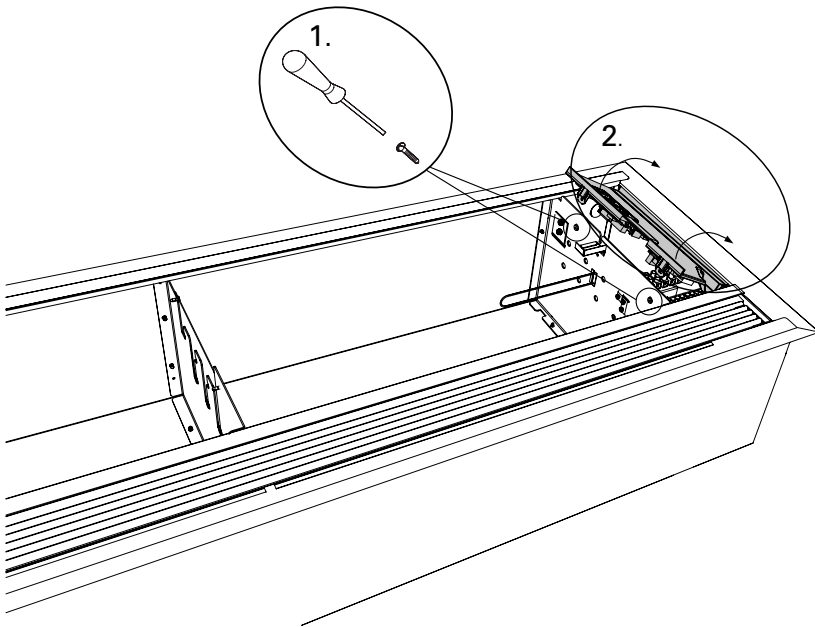
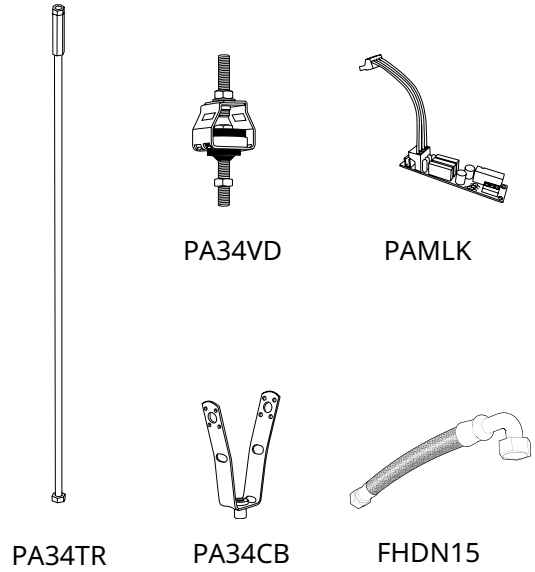

Fig. 4: Terminal box and control panel inside unit.

Accessories

PA34TR15	AREC3210Cx, AREC3215Cx, 1 m/3.3 ft
PA34TR20	AREC3220Cx, 1 m/3.3 ft
PA34CB15	AREC3210Cx, AREC3215Cx
PA34CB20	AREC3220Cx
PA34VD15	AREC3210Cx, AREC3215Cx
PA34VD20	AREC3220Cx
PAMLK	AREC3200C
FHDN15	AREC3200CW



Type	Connection
VLSP15NF-NA	DN15 (1/2")
VLSP20-NA	DN20 (3/4")
VLSP25-NA	DN25 (1")

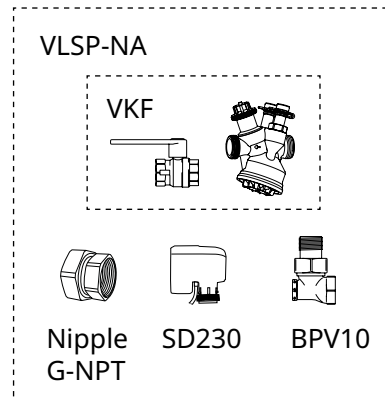

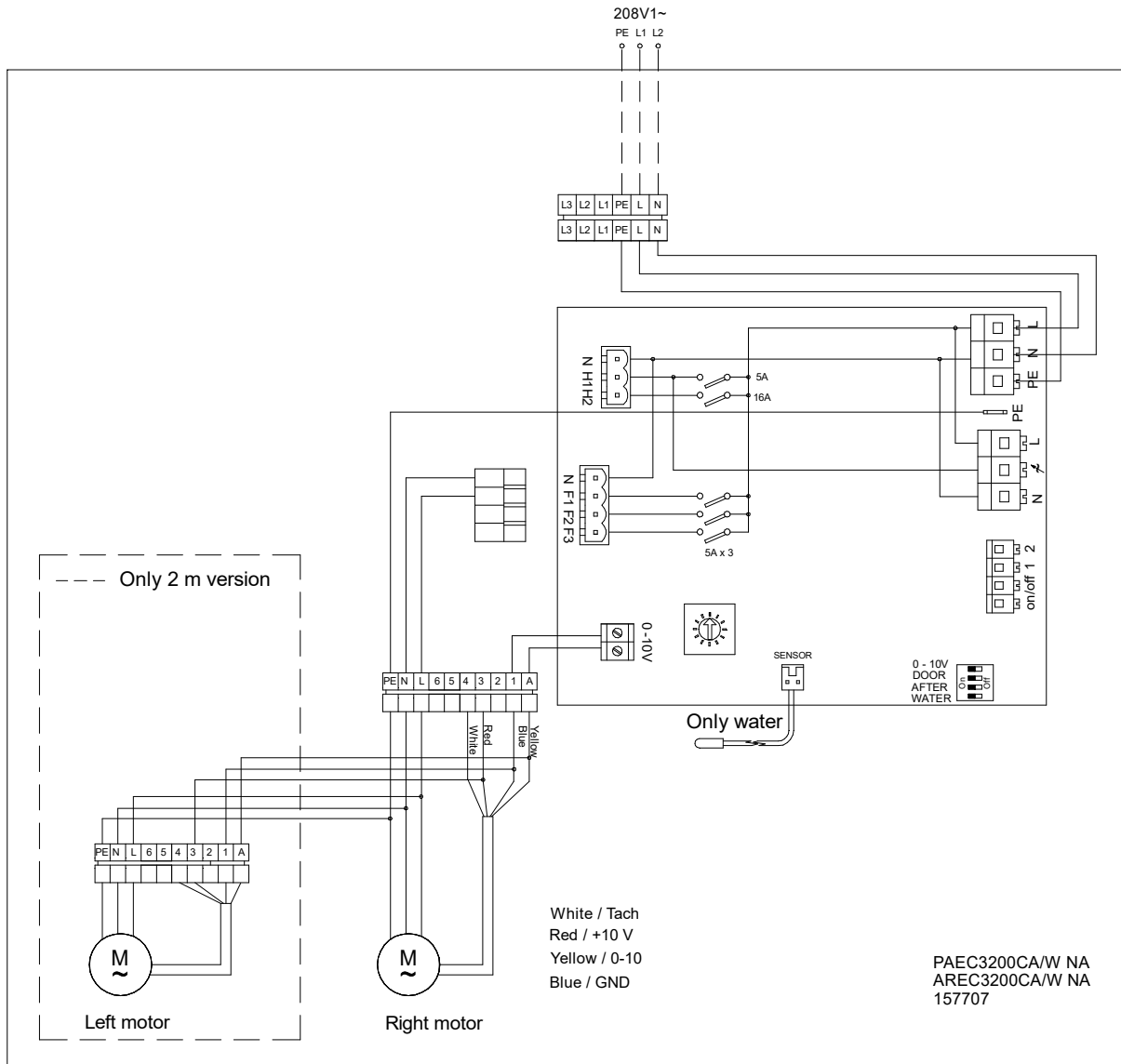

AREC3200CE-208V

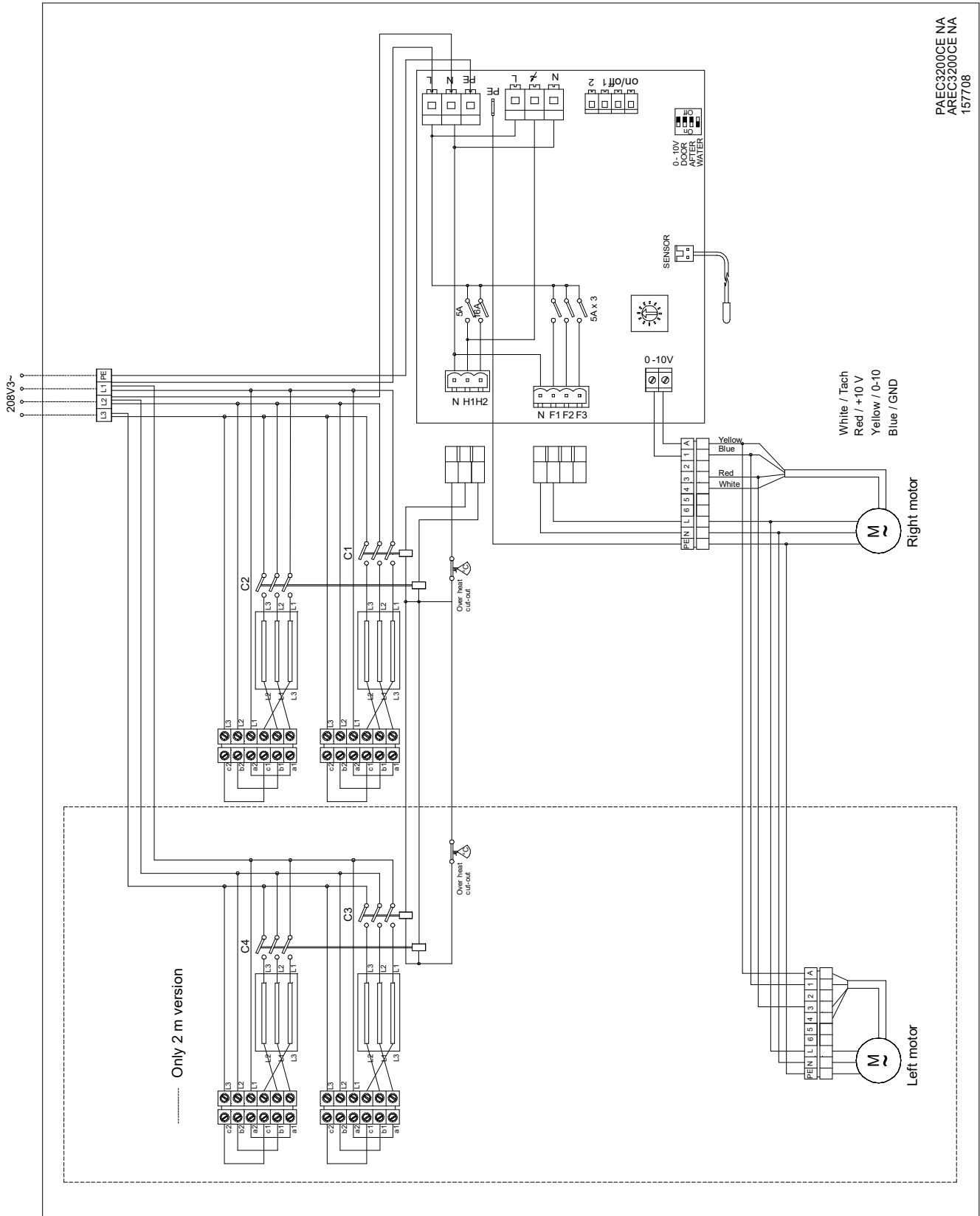

PAEC3200CE NA
AREC3200CE NA
15/7/08

AREC3200CE-480V/600V

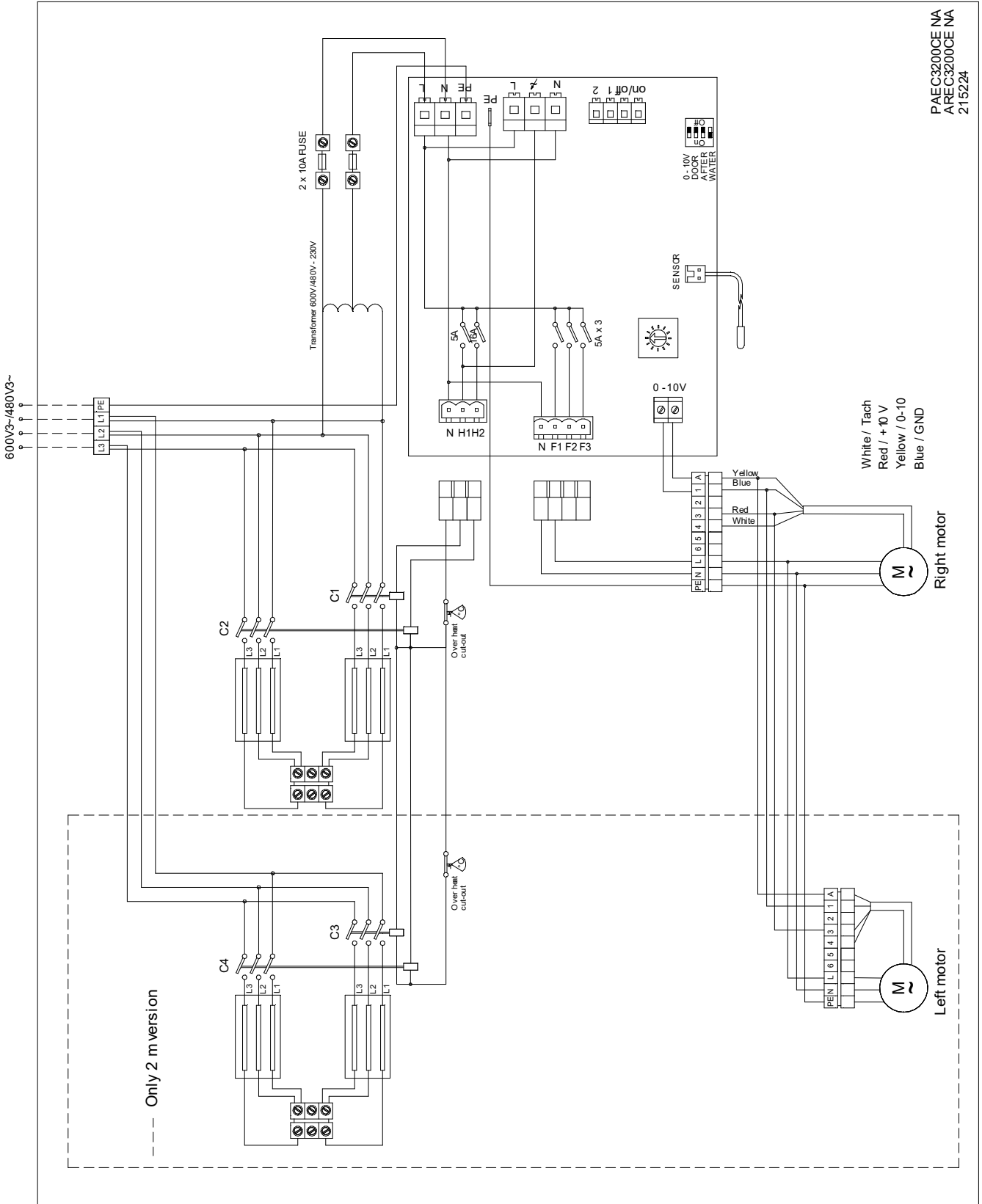

EN

- Read the safety instructions before performing installation and/or maintenance activities on the unit.
- Installation and/or maintenance activities on the unit may only be performed by qualified technical staff.
- The unit shall not be installed and used outdoors or in environments that are aggressive, or potentially explosive. At installation site make sure surrounding environment does not require higher IP classification of the equipment than what is stated on the data label of the unit.
- The unit must be connected in accordance with the applicable local requirements. Make sure that the unit's power supply voltage matches the local mains voltage. The unit's power supply voltage and maximum ratings are displayed on the data label placed on the unit.
- The unit shall be fused according to the table below.
- See also "Safety" on the English pages.

FR

- Veuillez lire les consignes de sécurité avant d'installer l'unité ou d'en effectuer l'entretien.
- L'installation ou l'entretien de l'unité doivent être effectués par un technicien qualifié seulement.
- L'unité ne doit pas être installée et utilisée à l'extérieur ou dans un environnement hostile ou potentiellement explosif. Au site d'installation, veuillez vous assurer que le milieu environnant n'exige pas une classification IP de l'équipement supérieure à ce qui est indiqué sur l'étiquette de données de l'unité.
- L'unité doit être branchée conformément aux exigences locales applicables. Veuillez vous assurer que la tension d'alimentation de l'unité correspond à la tension de secteur locale. La tension d'alimentation de l'unité et les calibres maximums sont indiqués sur l'étiquette de données placée sur l'unité.
- L'unité doit être protégée par un fusible conformément au tableau ci-dessous.
- Voir également la section « Sécurité » dans les pages en français.

ES

- Lea las instrucciones de seguridad antes de realizar trabajos de instalación y/o mantenimiento en la unidad.
- Los trabajos de instalación y/o mantenimiento en la unidad solo deben encomendarse a personal técnico cualificado.
- La unidad no debe instalarse ni utilizarse al aire libre ni en entornos agresivos o potencialmente explosivos. En el lugar de instalación, asegúrese de que el entorno circundante no requiera un equipo con una clasificación IP superior a la que se indica en la etiqueta identificativa de la unidad.
- La unidad debe conectarse de acuerdo a la normativa local vigente. Asegúrese que la tensión de alimentación de la unidad coincida con la tensión de la red eléctrica local. La tensión de alimentación y los valores nominales máximos de la unidad figuran en la etiqueta descriptiva de cada unidad.
- La unidad debe protegerse con fusibles según se indica en la siguiente tabla.
- Consulte también la sección «Seguridad» de la versión en español.

EN: Maximum Amperage on L1, L2 or L3 [A]	EN: Maximum fuse value [A]
FR: Intensité de courant électrique maximale pour L1, L2 ou L3 [A]	FR: Calibre maximum du fusible [A]
ES: Intensidad máxima en L1, L2 o L3 [A]	ES: Valor máximo del fusible [A]
≤ 10A	16A
≤ 15A	20A
≤ 20A	25A
≤ 25A	35A
≤ 35A	50A
≤ 50A	63A
≤ 65A	80A
≤ 80A	100A
≤ 102A	125A

Installation and operating instructions

General Instructions

Read these instructions carefully prior to installation and use. Keep this manual for future reference.

The product may only be used as set out in the assembly and operating instructions. The guarantee is only valid should the product be used in the manner intended and in accordance with the instructions.

Application area

AREC3200C is a compact air curtain for recessed mounting. The air curtain is available without heat, with electrical heating and with water heating. Recommended installation height for ambient and electrically heated units is 3.2 metres/10.5 feet and recommended installation height for water heated unit is 2.8 metres/9.2 feet. The air curtain has an integrated control system and can also be remote controlled.

Protection class for units with electrical heating: IP20.

Protection class for units without heating and units with water heating: IP21.

Operation

Air is drawn in from underneath and blown downwards shielding the door opening and minimizing heat loss. To achieve the optimum curtain effect the unit must extend the full width of the opening.

The grille for directing the outlet air is adjustable and is normally angled outwards to achieve the best protection against incoming air.

The efficiency of the air curtain depends on the air temperature, the pressure differential across the doorway and any wind load.

NOTE! Negative pressure in the building considerably reduces the efficiency of the air curtain. The ventilation should therefore be balanced.

Mounting

The air curtain is installed horizontally with the outlet air grille facing downwards as close to the door as possible, concealed in the false ceiling. The only visible part of the unit is the underside which is level with the ceiling. The service hatch must be accessible, nothing should prevent it being fully opened.

The unit is ready for suspension with threaded bars on its outside. The threaded bars can also be fixed on the inside of the unit e.g. when mounted on a solid suspended ceiling.

For the protection of wider doorways, several units can be mounted in series alongside each other. Minimum distance from outlet to floor for electrically heated units is 1800 mm/70.9 in.

Mounting on threaded bars outside the unit

1. The mounting brackets are fixed to the unit during transport. Loosen these, turn them around and screw into place on the unit according to fig. 1a.
2. Hang on threaded bars (M8) according to fig. 1b (accessory).
3. Adjust the height using the lower nut so that the frame is level with the ceiling. Lock using the upper nut.

Mounting on threaded bars inside the unit

1. The mounting brackets are fixed to the unit during transport. Loosen them and screw them into place inside the unit in the intended holes. In order to mount the brackets, remove the service hatch, outlet grille and covering plates.
2. Hang on threaded bars (M8) according to fig. 2b (accessory).
3. Adjust the height using the lower nut so that the frame is level with the ceiling. Lock using the upper nut.

Electrical installation

The installation, which should be preceded by an isolator switch with a contact separation of at least 3 mm/0.12 in, should only be wired by a competent electrician and in accordance with the latest edition of IEE wiring regulations. The control system is pre-installed in the air curtain.

Unit without heating or with water heating

The electrical connection is made on the top or side of the unit. Control (208V~) should be connected to a terminal block in the terminal box.

Unit with electrical heating

208V3~/480V3~/600V3~ power supply for heat and control (*1 *2) should be connected to a terminal block in the primary terminal box. See Fig. 4.

*1 480V3~/ 600V3~ Control supply is transformed via internal transformer to 230V~ and routed through 2x 10A fuses in the primary terminal box.

*2 208V3~ Control supply is connected internally through 2x 10A fuses in the primary terminal box.

The cable glands used must meet the protection class requirements. The largest cable diameter for the terminal block is AWG6.

See wiring diagrams.

Control options**Stepless airflow control with door contact/position limit switch**

When the door is closed the fan runs at low speed. When the door opens, the fan runs at high speed, set on the remote control or the control panel placed inside the service hatch. This control option gives low response time and the best protection.

Start-up (E)

When the unit is used for the first time or after a long period of non-use, smoke or an odour may result from dust or dirt which has collected on the element. This is completely normal and disappears after a short time.

Connecting the water coil (W)

The installation must be carried out by an authorised installer.

The water coil has copper tubes with aluminium fins and is suitable for connection to a closed water heating system. The heating coil must not be connected to a mains pressure water system or an open water system.

Note that the unit shall be preceded by a regulating valve, see Frico valve kit.

The connections to the heating coil must be equipped with shut off valves to allow trouble-free removal. Water coil is equipped with a drain and a vent valve. The water coil is connected via connections with dimensions DN15 (1/2"), outside thread, inside the unit. Knockouts are placed on the top and the side of the unit.

NOTE: Care must be taken when connecting the pipes. Use a pipe wrench or a similar tool to grip the air curtain connections to prevent straining of the pipes and subsequent water leakage during connection to the water supply pipe-work.

Adjustment of the air curtain and airflow

The direction and speed of the airflow should be adjusted considering the load on the opening. Pressure forces affect the airstream and force it inwards towards the premises (when the premises are heated and the outdoor air is cold).

The airstream should, therefore, be directed outwards to withstand the load. Generally speaking, the higher the load, the greater the angle required.

Basic setting fan speed

The fan speed when the door is open is set using the control. Note that the airflow direction and the fan speed may need fine adjustment depending on the loading of the door.

Filter (W)

The water coil is protected against dirt and blockage by an internal air filter which covers the coil face.

Service, repairs and maintenance

For all service, repair and maintenance first carry out the following:

1. Disconnect the power supply.
2. The service hatch is opened by loosening the snap fixings located on the bottom of the unit (turn 90°). The hatch must be held when the snap fixings are loosened. See fig. 3a and 3b.
3. After service, repairs and maintenance close the service hatch and make sure that the snap fixings lock securely.

Maintenance

Unit with water heating

The appliance filter should be cleaned regularly to ensure the air curtain effect and heat emission from the device. How often depends on local circumstances. A clogged filter is not a risk, but the appliance function can fail.

1. Disconnect the power supply.
2. The service hatch is opened by loosening the snap fixings located on the bottom of the unit (turn 90°). The hatch must be held when the snap fixings are loosened. See fig. 3a and 3b.
3. Remove the filter and vacuum clean or wash it. If the filter is clogged or damaged, it may need to be changed.

All units

Since fan motors and other components are maintenance-free, no maintenance other than cleaning is necessary. The level of cleaning can vary depending on local conditions. Undertake cleaning at least twice a year. Inlet and exhaust grilles, impeller and elements can be vacuum cleaned or wiped using a damp cloth. Use a brush when vacuuming to prevent damaging sensitive parts. Avoid the use of strong alkaline or acidic cleaning agents.

Overheating

The air curtain unit with electrical heating is equipped with an overheat protection. If it is deployed due to overheating, reset as follows:

1. Disconnect the power supply with the isolator switch.
2. Determine the cause of overheating and rectify the fault.
3. Open the service hatch. Locate the red button next to the terminal box inside the air curtain. The 2 and 2.5 metre/6.6 and 8.2 feet units are equipped with two red buttons, one on the outside of each terminal box.
4. Press the red button until a click is heard.
5. Reconnect the unit.

All motors are equipped with an integral thermal safety cut-out. This will operate, stopping the air curtain should the motor temperature rise too high. The cut-out will automatically reset when the motor temperature has returned to within the motor's operating limits.

Temperature control

See control pages.

Replacing motor or impeller

1. Remove frame and side panel.
2. Remove the screw between motor and fan.
3. Disconnect the cables to the motor.
4. Remove the screws securing the motor and lift it out together with the impeller.
5. Install the new motor and/or the new impeller as above in reverse order.

Replacing heating elements/heating package (E)

1. Mark and disconnect the cables to the heating elements/package.
2. Remove the mounting screws securing the heating elements/package in the unit and lift the heating elements/package out.
3. Install the new heating elements/package in reverse order to the above.

Replacing the water coil (W)

1. Shut off the water supply to the unit.
2. Open the vent valve.
3. Open the drain valve.
4. When the water coil is empty, disconnect its connections.
5. Remove the covering plate.
6. Remove the mounting screws securing the coil in the unit and lift out.
7. Move the filter to the new unit.
8. Install the new coil in reverse order to the above.

Draining the water coil (W)

The drain valve is on the underside of the coil on the connector side. It can be accessed via the service hatch.

Troubleshooting

If the fans are not running or do not perform properly, check the following:

- The functions and settings of the built-in control system.
- That the intake grille/filter is not dirty.

If there is no heat, check the following:

- The functions, internal sensor and settings of the built-in control system.

For units with electrical heating, also check the following:

- Power supply to electric heater coil; check fuses and circuit-breaker (if any).
- That the overheat protection has not been deployed.

For units with a water coil, also check the following:

- That the water coil is vented
- That there is sufficient water flow and pressure.
- That incoming water is heated adequately.
- That the valves and the actuators are correctly installed and working.

If the fault cannot be rectified, please contact a qualified service technician.

Residual current circuit breaker (E)

When the installation is protected by means of a residual current circuit breaker, which trips when the appliance is connected, this may be due to moisture in the heating element. When an appliance containing a heater element has not been used for a long period or stored in a damp environment, moisture can enter the element.

This should not be seen as a fault, but is simply rectified by connecting the appliance to the main supply via a socket without a safety cut-out so that the moisture can be eliminated from the element. The drying time can vary from a few hours to a few days. As a preventive measure, the unit should occasionally be run for a short time when it is not being used for extended periods of time.

Packaging

Packaging materials are chosen with consideration to the environment and are therefore recyclable.

Handling of product at end of working life

This product may contain substances necessary for the functionality of the product but potentially dangerous for the environment. The product should not be disposed of mixed with general household waste but delivered to a designated collection point for environmental recycling. Please contact the local authority for further details of your nearest designated collection point.

Safety

- *For all installations of electrically heated products a residual current circuit breaker 300 mA for fire protection must be used.*
- *Keep the areas around the air intake and exhaust grilles free from possible obstructions!*
- *The unit must not be fully or partially covered as overheating can result in a fire risk!*
- *Lifting equipment must be used to lift the unit.*
- *This appliance can be used by children aged from 8 years and above and persons with reduced physical, sensory or mental capabilities or lack of experience and knowledge if they have been given supervision or instruction concerning use of the appliance in a safe way and understand the hazards involved. Children shall not play with the appliance. Cleaning and user maintenance shall not be made by children without supervision.*
- *Children of less than 3 years should be kept away unless continuously supervised.*
- *Children aged from 3 years and less than 8 years shall only switch on/off the appliance provided that it has been placed or installed in its intended normal operating position and they have been given supervision or instruction concerning use of the appliance in a safe way and understand the hazards involved.*
- *Children aged from 3 years and less than 8 years shall not plug in, regulate and clean the appliance or perform user maintenance.*

CAUTION — Some parts of this product can become very hot and cause burns. Particular attention has to be given where children and vulnerable people are present.

Control

The control system is integrated in the air curtain. The air curtain can be regulated with a remote control or by the control panel placed inside the service hatch.

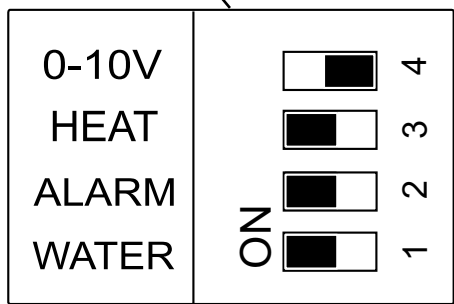
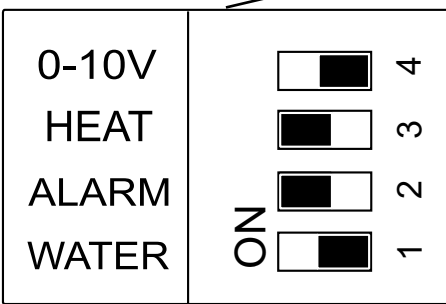
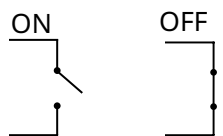
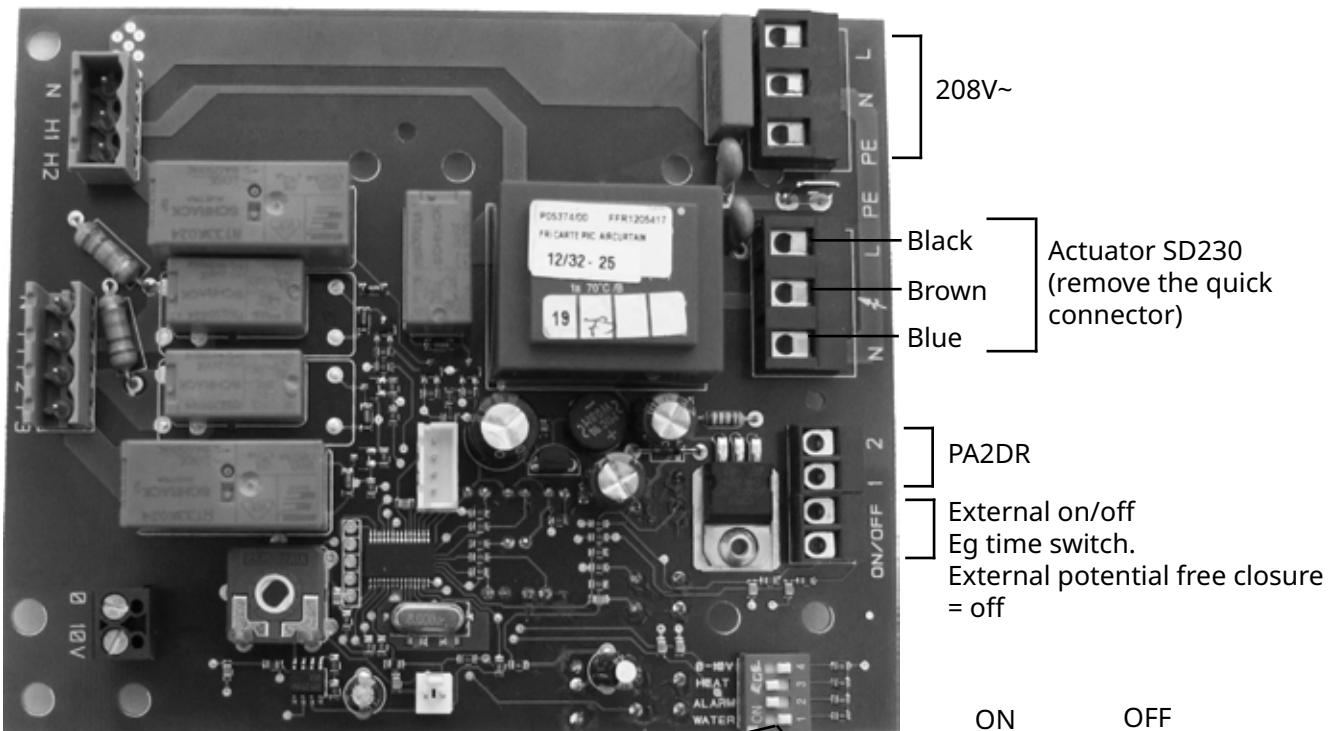
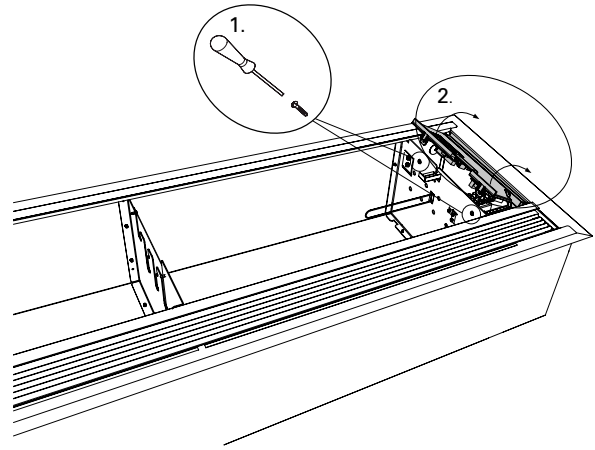

Factory setting dip-switches - Unit without heating or with electrical heating

Factory setting dip-switches - Unit with water heating

Dip-switch 3 is used for PA2DR.

Dip-switch 3 is used for PA2DR.

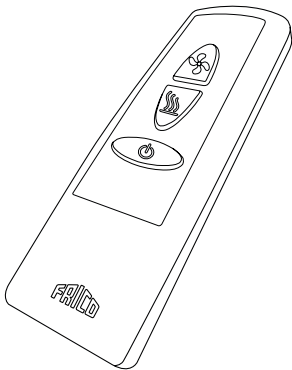
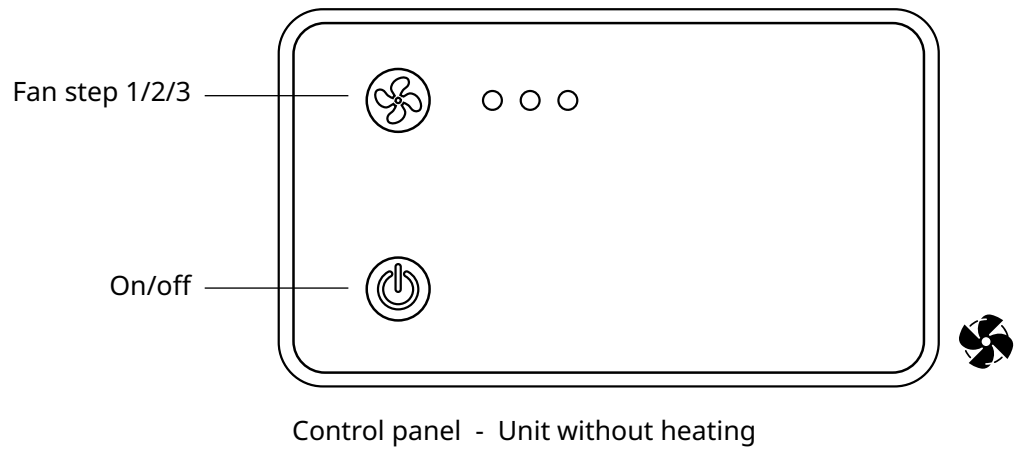
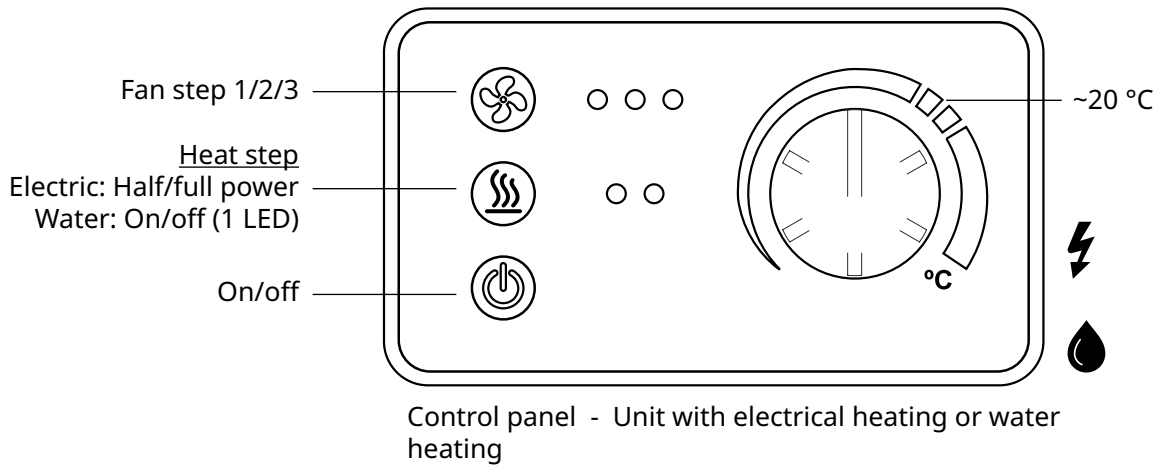

Remote control - on/off, fan steps and heating steps

Functional test

Functional test is started using the remote control.

Push
and



in 5 seconds

Fan and heatings steps are tested in 10-second intervals which is indicated by lighted LEDs. When the test is completed, all LEDs will flash for 30 seconds.

Temperature control

If the temperature exceeds 50 °C / 122 °F, the fan runs at full speed for 2 minutes to vent out the heat, if the temperature rises above 50 °C / 122 °F again during the following 5 minutes overheating alarm is deployed. The red LEDs flash and all the buttons are locked.

1. Disconnect the power supply with the isolator switch.
2. Determine the cause of overheating and rectify the fault.
3. Reconnect the unit.



**UK
CA**

CE

Main office

Frico AB
Industrivägen 41
SE-433 61 Sävedalen
Sweden

Tel: +46 31 336 86 00
mailbox@frico.se
www.frico.net

**For latest updated information and information
about your local contact: www.frico.net**