



SHOP DRAWING

ELECTRIC FURNACE SFECM SERIES



FEATURES

COLOUR

charcoal

FINISH

powdercoated

MANUFACTURING

- robust galvanized steel cabinet
- compartmentalized door providing easy access to all components
- disposable 20 in. x 20 in. air filter (included)
- compatibility mechanism for an auxiliary unit (included)
- 1 type of relay for all functions

ELEMENTS

modulating elements for increased comfort and separately framed allowing for quick and easy replacement

MOTOR

ECM (electronically commutated motor)

CONTROL

- easy-to-use modes
- Continuous ventilation button (low or high speed)
- Continuous heating button (min or max)
- simplified connection system
- mechanical relays allowing for easy and low-cost maintenance

INSTALLATION

- three possible installation positions: upflow, downflow or horizontal
- installation directly against a wall ("zero inch" clearance)
- possible installation with 3 conductors



COLOR:

TYPE	QTY	MODEL	KILOWATTS	VOLTS	AMP.	HP	SPEEDS	ACCESSORIES

TECHNICAL DRAWING

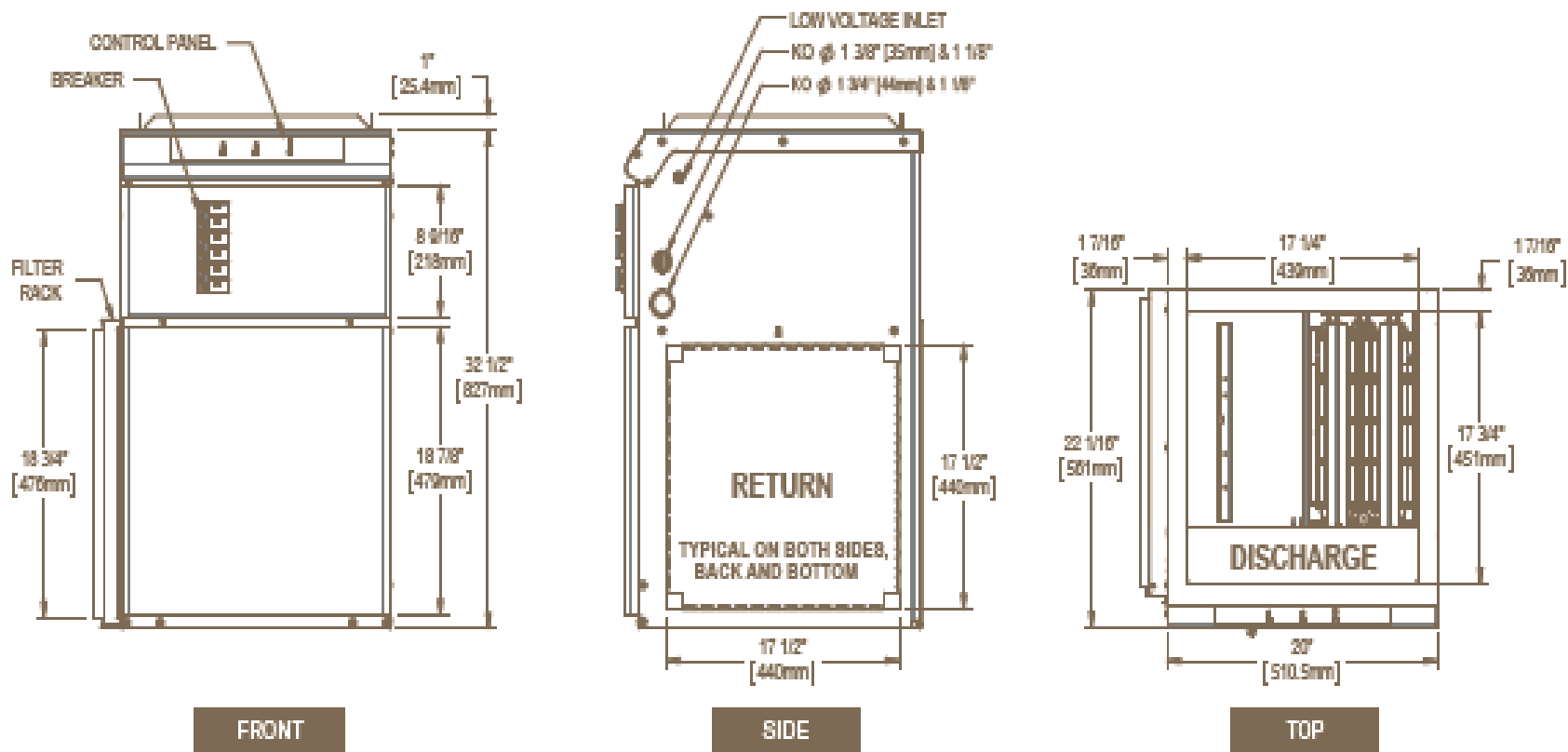

MODEL	DESCRIPTION	DELIVERY TIME

COMMENTS:	PROJECT:	
	ARCHITECT:	
	ENGINEER:	
	CONTRACTOR:	
	DISTRIBUTOR:	
	DATE:	